

# Robotronics

*The Leader In Safety Education Products*

1610 West 1600 South Springville, UT 84663  
Phone: 801-489-4466 FAX: 801-489-8241

## Curby the Recycling Robot™ Operating Manual



Version 6.4

---

# Curby the Recycling Robot™ Operating Manual

**Congratulations** on your purchase of a ROBOTRONICS, Inc. robot. Your robot has been carefully constructed of the highest quality components. Its' design is the result of years of experience building robots. You will find it an extremely effective spokesman for your organization. It is built for ease of operation, maintenance and repair. It is built so that you can easily expand its' functions making its' usefulness grow, as your needs grow.

Please read this manual carefully. It will help you make the most of your robot. Attention to maintenance will greatly prolong the life of your robot. Most problems you encounter will be minor and the manual will provide an answer. Please feel free to contact us if you have unanswered questions relating to operation, maintenance, and repair. Also, if you have technical questions relating to expanding the functions of your robot, we would be most happy to help.

Sincerely,

**ROBOTRONICS, Inc.**

# Contents

<b>Warranty Information</b> .....	1
<b>Part 1 General Operating Instructions</b> .....	3
Operating Hints .....	3
Set Up and Getting Started .....	4
Transporting The Robot .....	6
<b>Part 2 Subsystems of the Robot</b> .....	7
<b>A. Radio Control System</b> .....	8
Radio Control Operating Instructions .....	8
Radio Control Transmitter (Diagram) .....	9
Radio Control Transmitter Controls .....	10
Nickel Metal Hydride(NI-MH)Transmitter Battery .....	11
Charging of the NI-MH R.C. Transmitter Battery (Diagram) .....	11
Charging Adapter for Charging Extra NI-MH Battery.....	12
110 Volt Power Supply (For Radio Control) .....	12
<b>B. Robot Battery System</b> .....	13
Robot Battery Charger.....	14-15
<b>C. Voice System</b> .....	16
Location of Voice Units.....	16
Belt Transmitter .....	17
Robot Receiver.....	18
151 System (Robot TX and Belt 151 Receiver).....	19
Voice System Troubleshooting.....	20
<b>D. Cassette Tape and Radio System</b> .....	22
<b>E. Siren</b> .....	23
<b>F. Drive Motor System</b> .....	24
<b>G. Arms and Hands Motors System</b> .....	26
<b>H. Eyelids and Eyes Left and Right</b> .....	27
<b>I. Special Features</b> .....	28
(Lid Movement, Mouth Flashing Lights	
<b>J. Voice Modifier (Pitch Shifter)</b> .....	29
Voice Modifier (Diagram).....	30
<b>K. Water Squirter System</b> .....	31-32

Water Squirter System (Diagram) .....	33
<b>Part 3 Assembly &amp; Disassembly</b> .....	<b>34</b>
<b>Part 4 Maintenance</b> .....	<b>35</b>
Painting of the Body .....	36
Repair of the Body.....	37
Storage.....	38
<b>Part 5 Appendix</b> .....	<b>39</b>
Robot Circuit Diagram .....	40
<b>Robot Parts Identification</b> .....	<b>41</b>
Inside View (From Back) .....	42
Main Board .....	43
Main Electronics Panel Inside .....	44
Fuse Block Detail.....	45
Eyes Assembly .....	46
Eyes and Hands Servo Board (Circuit Board In Mouth) .....	47
Lower Base Inside View and Bottom View .....	48
Robot Base Bottom View.....	49
Notes Section * .....	50
Technical Tips Section * .....	51

\* These sections can be used to place additional notes that you would like to record, during your use of the robot.

## Limited Warranty

All robots and accessories have a limited 6-month warranty, which covers all parts and labor. This period covers the normal burn-in for electronic components. Experience has shown that this warranty period catches most component defects and other possible flaws. If you have a problem, we are anxious to help. Our desire is to be certain you receive a quality product and excellent service.

Warranty work is specifically limited to correction of defects by repair or replacement of faulty equipment or parts. The robot shall be repaired or replaced at Seller's option. Equipment returned to the factory for repair must have pre-authorization from our service department and must be sent freight pre-paid, and will be returned freight pre-paid by UPS ground or common carrier. If you need parts sent by air shipment you will be responsible to pay the additional shipping charges.

In no event shall ROBOTRONICS, Inc. be liable for any incidental or consequential damages in connection with or arising from the use of the robot, this manual or any procedures herein.

The buyer is further responsible to ensure that proper and complete training be given to those operating the robot system as all aspects of such operation cannot be covered in a brief manual such as this.

In no event shall ROBOTRONICS, Inc. be liable for any incidental or consequential damages in connection with or arising from the use of this manual or any procedures contained herein.

### If You Have A Problem

- Call our service department and explain the problem. **The phone number is (801) 489-4466.** Most difficulties are minor and can be solved easily over the phone. If possible, have the robot near the phone when you call.

---

**Important:** Have the robot serial number and model number ready. This will help our technician identify the model of robot you have. The serial and model number sticker is located on the robot frame on the right side. In the Appendix, the Lower Robot - Top View shows the location of the serial number sticker.

---

Record the vital information from your robot here for future access

Date Received: \_\_\_\_\_  
Customer Number: \_\_\_\_\_  
Robot Model Number: \_\_\_\_\_  
Robot Serial Number: \_\_\_\_\_  
Brand of Radio Control: \_\_\_\_\_  
Frequency of Radio Control: \_\_\_\_\_  
Voice Frequencies  
Operator Transmitter: \_\_\_\_\_  
Operator Receiver: \_\_\_\_\_

- Upon the receipt of your product, save all packing materials to return the product if needed.
- If you must return a part or the robot for repair, pack it carefully and send it prepaid according to instructions. You must obtain a return authorization number from the service department before shipping the robot or a part to the factory.
- Parts of the robot are best sent by a carrier such as UPS, Fed. Ex. or U.S. mail, because shipping is based on the actual weight of the package. Be sure to insure the shipment for the correct value. A freight company such as Roadway should be used only for the complete robot, because their shipping charges are based on 100 pound minimums.
- For international shipments, you will be responsible for paying customs duties, taxes and other fees. The shipment must be labeled on the paperwork and on the outside of the container that it is “**For Educational Purposes**”. If it is a “**warranty replacement**” or a “**repair return**” this also must be indicated both ways on the customs documentation. Contact your customs agency on how to document the shipment correctly to avoid unnecessary customs charges.

### **After The Warranty Repair and Help**

Our technical staff is always available to help with your questions. Again, most problems are easily solved. The robot design is very modular to make removal of a part of the robot very easy. For example the main electronics box, which houses most of the electronic circuitry, can be removed from the frame of the robot. If you do need technical help or replacement parts, call our Service Dept. We can usually ship them the following day you call. Please call our service department for a return authorization number before sending a part or your robot in for repair or modifications.

Service Department phone number: 801-489-4466.

# Part 1 General Operating Instructions

## OPERATING HINTS

ROBOTRONICS, Inc. robots are a unique and exciting tool in the hands of a skilled and trained operator. The operator provides much of the excitement the robot conveys. The selection and training of the operator should be done carefully, so as to provide a person with good judgment and an outgoing personality. The operator is the single most important feature that the robot has. Nevertheless, with a little practice anyone can learn to operate the robot and even those with a shy personality can be very effective using the robot. The following points will help in your operation of the robot.

- Operate the robot with charged batteries in the transmitter and robot.
- Never operate the robot out of line-of-sight.
- The operator must have the radio control in their hands when the robot is on. If you need to set the radio control down, turn the robot off first.
- Always have a trained person posted near the robot to help in crowd control, and to protect the robot from vandalism. This person is also available to answer questions and interact with the robot.
- Operating distance should never exceed 100 feet. When moving the robot through crowds, the robot should be operated slowly and smoothly without any sudden changes of direction. Walls, turns, and other obstacles are hazards to be avoided. Safe clearance should be maintained between these obstacles and the robot.
- Never leave the robot "ON" when unattended or in direct sunlight for extended periods of time.
- The robot is designed to be operated on hard, smooth surfaces and carpet. Avoid extra deep shag carpet, dirt, gravel, or grass surfaces. Avoid steep inclines or large uneven surfaces such as curbs, gutters, or uncovered electrical lines.
- When using the robot on a stage, the area just in front of the stage should be clear of children for about 10 feet.
- When attempting to operate the robot for the first time, do so in a large flat area without obstacles. The operation of the controls should be done in a smooth, fluid manner. Avoid jerking starts and stops or overreacting to the controls. When first practicing movement, it is sometimes helpful to follow behind the robot, as robot movement will match stick movement. (Controls respond opposite when the robot is facing the operator.)

The robot can be a highly successful tool for education and entertainment. Appropriate jokes, stories and general conversation can be very effective. Children of all ages are strongly attracted to the robot. They will talk to it, hug it, kiss it, and generally treat it as a good friend. The smaller sized robots are very effective with children. They are light in weight and just the right size to communicate with children. The most important ingredient to the use and effective operation of the robot is common sense. The following instructions will help you get set up and start using the robot.

# GETTING STARTED

## 1 Read the Manual

Read and study the manuals and instructions completely before operating the robot.

## 2 Charge the Batteries

Be certain that the robot battery and radio control transmitter batteries are fully charged before operating the robot. Install the robot battery in to the robot. When installing the battery or removing it, avoid hitting any metal with the battery posts.

1. Position the robot battery so that the posts face the rear of the robot. In this position, the battery wire will naturally run to the robot battery connector.
2. Connect the robot battery connector to the robot connector. Red will go to red and black to black. This connection is polarity protected and can be connected only the correct way.
3. Secure the battery in place with the battery strap. Adjust the clip on the strap if necessary so that when you put the two clips together, the strap is holding the battery in place tight.



### **CAUTION**

**The robot battery posts should never contact the metal of the main electronics box or the metal of the drive base. This will result in damage to electronic components especially inside the main electronics box.**

## 3 Turn on the Radio Control

Turn the Radio Control Transmitter on first and then turn the robot on. Check that the Radio Control Transmitter battery level meter reads to the right.

## 4 Turn on the Robot

The ON/OFF switch is located underneath the robots' back door. The switch has three positions; On(right)/Off/Recharge(left). Check all of the functions. You can now operate many of the functions of the robot without any other equipment.

## 5 Turn on the Voice Equipment

Pull out the voice units and headset from the carry case. Put 9 Volt alkaline batteries in them (We suggest Eveready because of better fit), and attach the headset plugs to them. On the 151 Receiver, the headset plugs into headphones.

## 6 Test all of the functions

Test all of the robot's functions: voice, tape, siren, eyes, and movement for proper operation. Adjust the voice system and tape player volume control if needed. The robot is now ready to operate.

## 7 To turn off the system

To turn off the system, first turn the robot power switch to the "OFF" position. Finally turn off the 151 Voice Receiver, Voice Transmitter, and Radio Control Transmitter. To avoid a squelch sound in the headset, the 151 receiver can be turned off before the robot.



NOTE:

*The smooth and efficient operation of the robot will come with just a few short hours of practice. When attempting to operate the robot for the first time, do so in a large flat area without obstacles. It is recommended that this training take place away from crowds that may distract from your learning process. The operation of the controls should be done in a smooth, fluid manner. Avoid jerking starts and stops or overreacting to the controls. When first practicing movement, it is sometimes helpful to follow behind the robot as robot movement will match stick movement. (Controls respond opposite when the robot is facing the operator.)*

## TRANSPORTING THE ROBOT

Before transporting the robot, make sure that the robot battery strap is tight and secure so that the battery cannot move at all. Removing the robot battery from the robot is also an option. This can prevent the robot battery from damaging the internal parts of the robot or the posts from touching any metal, which can cause a short.

The vehicle that you use to transport the robot should have adequate shock absorption. Vans, Cars and Trucks have good enough shock systems. Transporting the robot in a trailer is not recommended because trailers typically do not have the same level of shock absorption as a car or van. A good rule of thumb to follow is that if the vehicle is adequate for transporting a computer, it should also be fine for the robot. You can leave the robot on the transport cart while the robot is in transit, to keep the robot from rolling around. Have the robot cover on the robot to keep the body from getting scratched.



**CAUTION** Stand the robot up, and secure it, if possible. If you do lay it down, the robot battery must be taken out of it or it could cause damage to the robot even if the strap is tight. The strap cannot hold the battery in a position other than its normal position.

---

### Using the Transport Cart

1. It is best to use two people to load and unload the robot from the cart.
2. Roll the robot on to the cart backward. You will need to lift the wheels over the edge of the plastic to get the wheels to set into the molded recesses.
3. Put the strap around the lower portion of the robot, below the mouth. The hooks can go on the center bar of the cart.
4. Tighten the strap until the robot is secure. Do not over-tighten to avoid damaging the plastic.
5. Lock the ratcheting mechanism.
6. When done transporting, just release the ratchet and slide the strap off. Steady the robot while doing this.



## Part 2 Subsystems of the Robot

Functionally, the robot is made up of the following basic subsystems:

- A. Radio Control System
- B. Robot Battery System
- C. Voice System
- D. Cassette Tape and Radio System
- E. Siren
- F. Drive Motors
- G. Arms and Hands Motors System
- H. Eyelids and Eyes Left and Right

### **Optional Features**

- I. Special Features
- J. Voice Modifier
- K. Water Squirter

The systems block diagram (Robot Circuit Diagram), found in the Appendix shows how the various subsystems and their components are interrelated.

Following are explanations of each subsystem, some operating instructions, and trouble shooting hints where appropriate.

## A Radio Control System

The Radio Control System consists of the control transmitter unit held by the operator and the receiver with its associated components in the robot.

The Radio Control Transmitter converts movements of the control sticks and switches into a coded radio signal, which is transmitted by radio to the Radio Control Receiver within the robot. The signal is received and then decoded by the microcontroller, which is on the main circuit board in the vehicle. The micro-controller controls functions based on what was sent from the radio control transmitter.

### **RADIO CONTROL OPERATING INSTRUCTIONS**

Refer to the diagram showing the radio control transmitter for the location of controls. Check all of the trim adjustments on the transmitter and make sure they are in their center position. Extend the Radio Control Transmitter Antenna 1/4 to 1/2 way. Turn the Radio Control Transmitter on first and then turn on the main robot power switch. It is necessary for the robot to always have an operating signal when it is on, if there is no signal you will not have full control of the robot.

The right hand joystick controls movement of the robot's drive wheels. Pushing the stick forward will cause the robot to move forward. Pulling the stick back will cause the robot to move backward. Moving the stick to the right or left will cause the robot to turn to the right or left respectively. Movement is fully proportional so any variation or combination of movement is possible. The horizontal and vertical trim tabs to the left and below the joystick should typically be left in the center. They are for centering the drive and should be adjusted only if the robot starts moving slightly. Just move the slider until the robot stops moving.

Control of the left and right eyelids is on Switch bank 1, switches #6 and #7 (See the radio control diagram) found on the upper left hand of the Radio Control Transmitter. The eyelids can be operated together with switch #6. Pushing this switch closes the eyelids for blinking of the eyelids. You can do a wink with switch #7. The eyes left and right move when you turn the left joystick left and right. Forward and back movement of the joystick controls the eyebrows.

For a detail of other functions, see the radio control diagram on the next page. All of these functions are labeled on the radio control itself.

A charge plug is provided on the transmitter for recharging its internal battery. The transmitter power switch must be in the off position before charging the batteries. A charge light on the charger will come on while charging.

# RADIO CONTROL TRANSMITTER (Robbe-Futaba F-14)

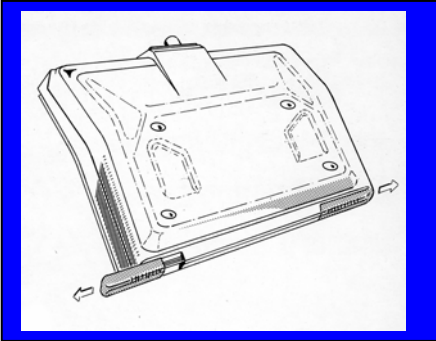
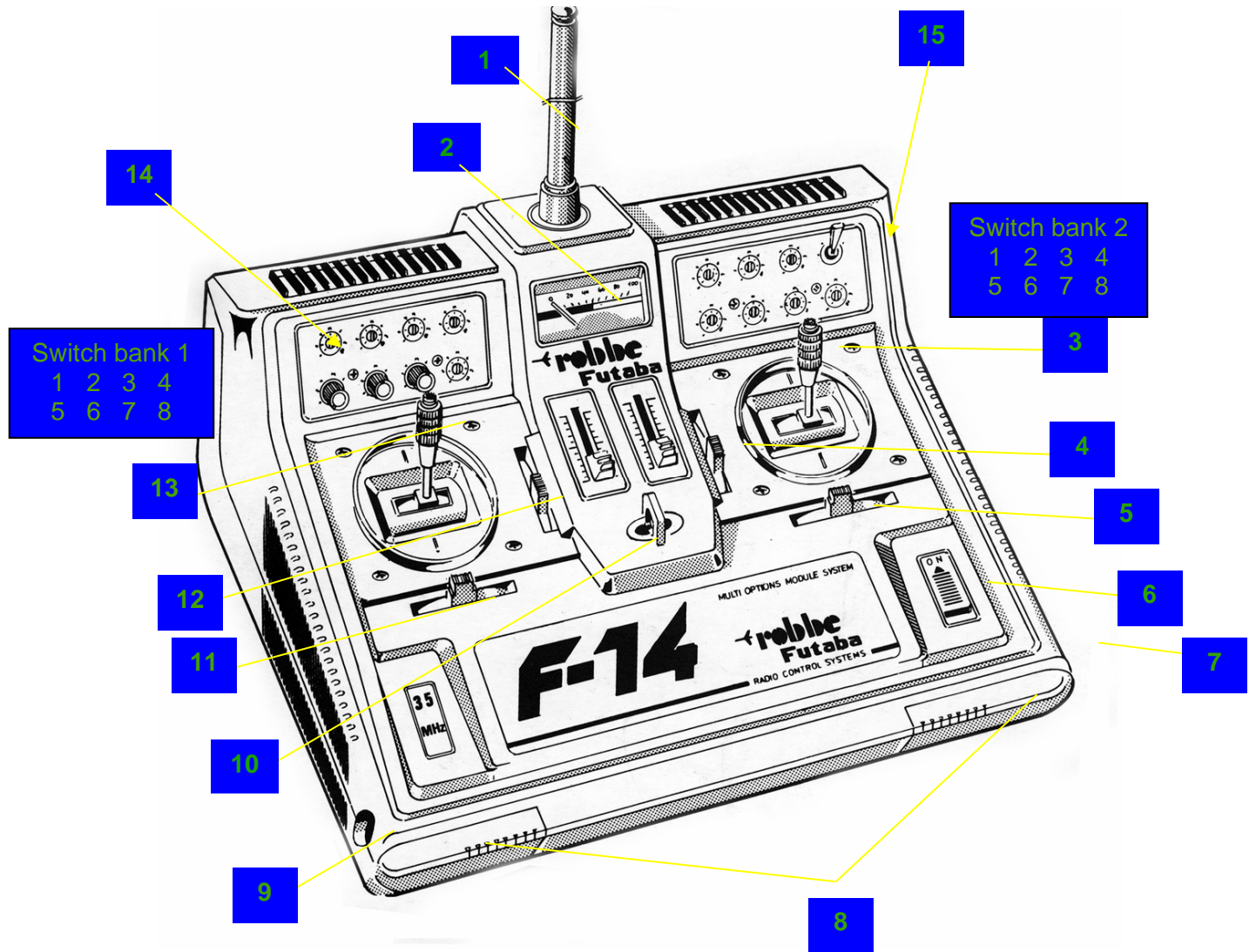

To remove back cover, slide the tabs as shown.

# RC TRANSMITTER CONTROLS

1. Telescopic Transmitter Aerial.
2. Transmitter Battery Voltage Meter (Expand Scale Voltmeter)
3. Right control Stick-  
Up and Down – Robot drive motors, forward and reverse.  
Right and Left – Robot drive motors steering. Left and right turns.
4. Forward/Reverse Trim lever for right control stick. Normal = Center. Neutralizes the drive motors. If the robot is moving slightly slide this a few clicks until robot stops moving.
5. Left and right Trim lever for right control stick. Normal = Center. Neutralizes the drive motors. If the robot is moving slightly slide this a few clicks until robot stops moving.
6. On/Off switch
7. Recharge jack. Plug the RC battery charger in here to recharge the internal battery. The charge light on the charger will come on.
8. Sliding tabs to remove the back cover. Slide both tabs off and take the back cover off.
9. Antenna storage.
10. Neck strap connecting hook.
11. Left and right Trim lever for left control stick. Normal = Center. Trims the Eyes position.
12. Forward and Reverse Trim lever for the left control stick. Normal = Center. Trims the eyebrows position.
13. Left Control Stick  
Left and right movement – Movement of the eyes left and right.  
Up and Down – Movement of the eyebrows up and down.
14. **Switch bank 1**
  5. Back- Siren / Forward- Tape Player
  6. Back- Wink -close left eyelid momentary / Forward- Left Hand
  7. Back- Wink -close right eyelid momentary / Forward- Right Hand
  8. Back- Lid Up and Down / Forward- Water Squirter option

## THE Nickel Metal Hydride (NI-MH) RC TRANSMITTER BATTERY

The NI-MH RC transmitter battery will last about 5-6 hours on a full charge. Charge the battery for **16 hours**. A charge jack is provided on the transmitter for recharging its internal batteries. This round jack is located on the right side of the radio control. (See the radio control diagram) The RC power switch must be in the off position when the charger is plugged into it and must remain in the off position while charging. A light on the charger will be on, when charging.

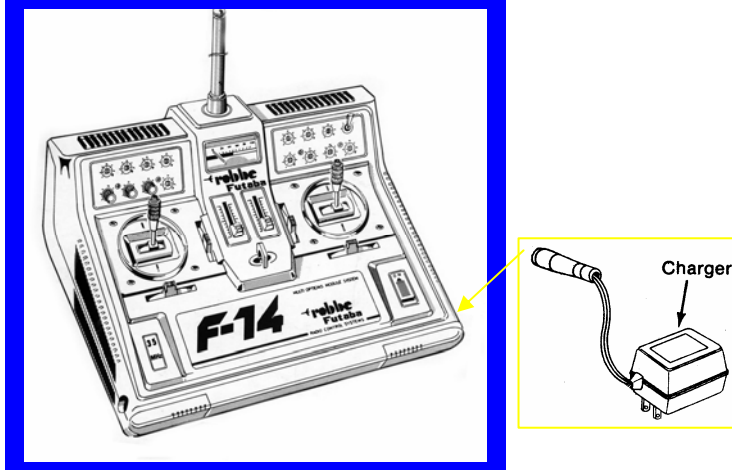

**Caution:** Do not overcharge the batteries as this could cause permanent damage to the transmitter batteries. (Doubling the normal charging time is the type of over charging that is meant here, and the battery getting hot.) When the battery level needle goes in the red, the robot should be turned off because the robot could act erratic without the transmitter signal.

To avoid a RC battery going dead during a presentation, start the program with a fully charged battery or be aware of how much charge there is left in the battery. If you have an extra battery or the optional 110 Volt RC Power Supply, you can connect one of these and keep going.

To install the NI-MH battery pack you need to take the back cover off the RC.

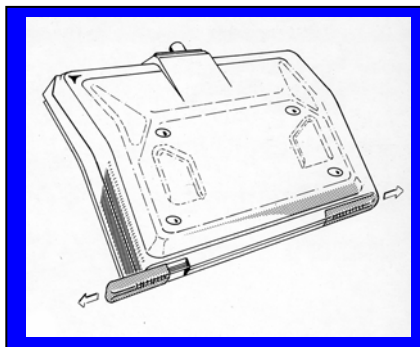

To remove back cover,  
slide the tabs as shown.

### NI-MH RC Battery and Charger Specifications

NI-MH RC transmitter battery	9.6 Volts	1300mAH
NI-MH RC transmitter battery charger	11.6 Volts	130mA

### Adapter for Charging an Extra NI-MH RC Transmitter Battery

If you have an extra NI-MH RC battery, you can charge this outside the RC. You may need to do this while you are using the robot or if you need to charge both batteries at the same time. The adapter needed to do this is in the control case or it is on your charger. It has a white connector on one side and a connection on the other end that will go directly to your battery. If the barrel adapter is currently on the charger, disconnect it and connect the other adapter. The charging time is still 14 hours.



### 110 Volt RC Transmitter Power Supply Option

The 110V RC Power Supply is a power unit that plugs into a standard electrical outlet and in to the RC transmitter. This allows you to have continuous power without using batteries. This connects into the same connection as the battery. To make the connection you need to take the battery door off the RC. The wire feeds through a slot in the battery door. When you re-close the case be sure that the wire is not pinched. With this option, you do need to stand near an electrical outlet or have an extension cord.



## B ROBOT BATTERY SYSTEM

### ROBOT BATTERY

The battery in the robot is a rechargeable sealed lead-acid Gel type battery **12 Volt 33AH**. This type of battery is very dependable and safe. It can be repeatedly charged and discharged.

#### **How to Recharge**

1. To recharge the robot battery, connect the charger to the recharge jack on the back of the feet. Move the switch on the robot to the recharge position.
2. Plug the line cord of the charger into a 110-volt AC outlet. Leave the rear door open during charging for ventilation. Keep the AC power connection as short as possible especially when using an extension cord.
3. The red LED will come on during charging and the green when the battery is charged and ready to use. Both red and green on indicates that you are in the middle stage of charging.
4. To charge a battery outside the robot, connect the charger wires to the battery, red to the red (POSITIVE +) post and black to the black (NEGATIVE -) post.

The robot is supplied with an automatic type battery charger. This will recharge the battery full in about 8 hours depending on how long you have operated the robot. It will not overcharge the battery if left "ON" indefinitely. It goes to a float charge mode once the battery is fully charged.

#### **Taking Care of the Robot Battery**

- The number one rule for battery care is to keep the batteries fully charged at all times.
- Like all batteries, there is some discharge that occurs every day. Because of this you should charge up the battery **monthly** during periods when the robot is not being used.
- Also, the automatic battery charger can be left connected for extended periods of time to keep the batteries at full.
- It is a good practice to rotate the batteries if you have two or more.
- For a battery that is outside the robot, store the battery on a wood or rubber surface not concrete floors.

#### **Caution**



If the wires to the battery have been removed, observe properly polarity when re-connecting. The red wire goes to the positive terminal and black wire to the negative terminal. Damage to electronics could result if the polarity is wrong.

#### **Important**

**Charge the battery to a full charge right after each use of the robot and monthly when not in constant use.**

### ROBOT BATTERY CHARGER

The charger supplied with the robot is designed to both recharge your battery, and extend your battery's life. It produces 12 Volts DC at a full 6 Amps. It will charge the battery in about 8 hours depending on how long you have used the robot. After the battery is charged, the green LED will come on and the battery is ready to use. At this point the charger is charging at a FLOAT or maintenance rate. At this rate you can leave the charger connected for extended periods of time.

## Charge Pro Model 2606A 6 Amp Battery Charger

### Status Indicating Lights

**Red on**-The battery is discharged and is being recharged at the maximum 6 Amp rate of the charger (stage 1).

**Red and green both on**-The battery is charging at the stage 2 rate of 1.5 to 5 Amps.

**Green on**-Your battery is charged and ready to use. It is now on float charge (stage 3).

### Personal Safety Precautions

## Warnings

### HAZARD OF EXPLOSIVE GAS MIXTURE

When charging, a lead acid battery gives off hydrogen gas. The Gel type battery is a lead acid battery with pressure relief type vents. Although it only gives off a small percentage of the gas that a wet lead acid battery does, the following precautions should be observed:

1. Charge the battery in a dry, well ventilated area. This is why it is important that you leave the trunk or door open. You can also remove the battery from the robot.
2. Do not position your face over the battery, at any time while making connections.
3. Do not smoke, strike a match, or cause a spark in the vicinity of the battery during charging.
4. Always unplug the AC supply cord before connecting or disconnecting the charger leads from the battery.
5. Do not drop a metal tool onto the battery.
6. Do not expose the charger to rain.
7. Replace defective cords and wires immediately.
8. Do not operate this charger with a two bladed adapter plug or extension cord. Doing so can result in serious personal injury.
9. To reduce the risk of shock, connect only to a properly grounded outlet.

## **If the Battery is not taking a Charge**

Make sure that the charger is working by connecting it to a battery that is known to be good.

Leave the charger on for a few days and see if the battery starts taking a charge. Turn the robot on and try to operate it. Connect to the charger again. If it still will not take a charge, it's time to replace the battery.

## C VOICE SYSTEM

The Voice System consists of two separate communication links. One link transmits the operator's voice to the robot. When you speak into the headset mic, this audio goes to a transmitter on your belt. This audio is transmitted to a receiver in the robot. The audio signal then goes from the receiver through a mixing circuit on the main board. It is then fed into the amplifier which amplifies the signal through the robot's speakers.

The second voice link transmits the audio detected by the Mic element (located in the front of the robot) to the 151 receiver (which is worn by the operator). This is amplified and sent to the speaker in the operator's headset.

---

**Important:** The operator's transmitter and receiver should be kept as far separate as possible, such as on opposite sides of the operator's waist. Do not attach the units together, this may cause interference effects. The antennas should not be wrapped around each other or around the headset wire but should hang freely.

---

### Location of Voice Units

Voice Transmitter-	Operator wears
Voice Receiver-	On the main electronics box in the lower robot.
151 Transmitter-	On the frame in the robot. The robot mic connects to it.
151 Receiver-	Operator wears

Operator's Voice Transmitter, Receiver, and Headset

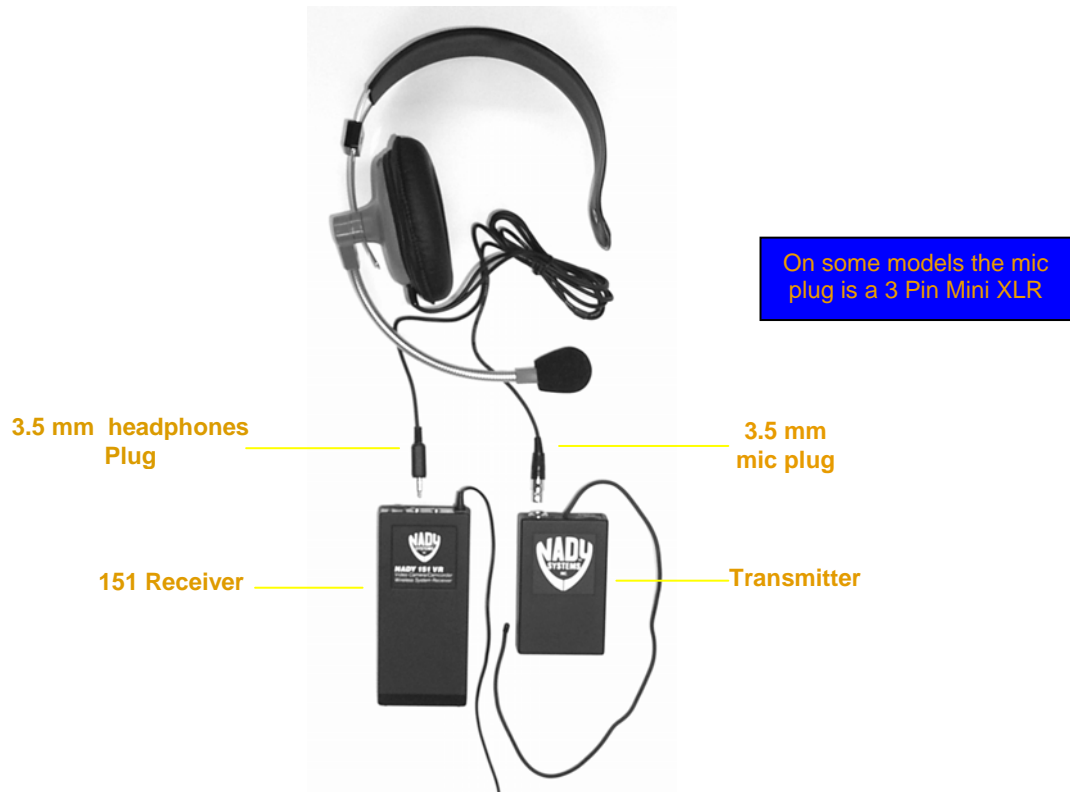

## How to Operate the Operator's Transmitter

1. Open the battery door.
2. Use a 9 Volt alkaline battery and insert it according to the diagram inside the battery compartment.
3. Place the headset on your head and adjust the microphone to approximately 1 inch from your mouth.
4. Plug the round connector from the headset into the top of the transmitter.
5. Move slide switches to the "ON" position.
6. On the UB-10 there is a volume adjust on the unit.

### Function of the LED

When turning on the power switch, with a fresh alkaline 9-Volt, the battery light will blink on momentarily and go out. This indicates that it is powering up and that the battery is good. Because the light is a low battery indicator, when the light is on constant, this indicates the battery is too low-below 7 Volts. Replace with a new alkaline battery.

**Tip:** The operator's voice units both have metal clips that contact the posts of the 9-volt battery. These must be bent out from time to time to keep this contact good.

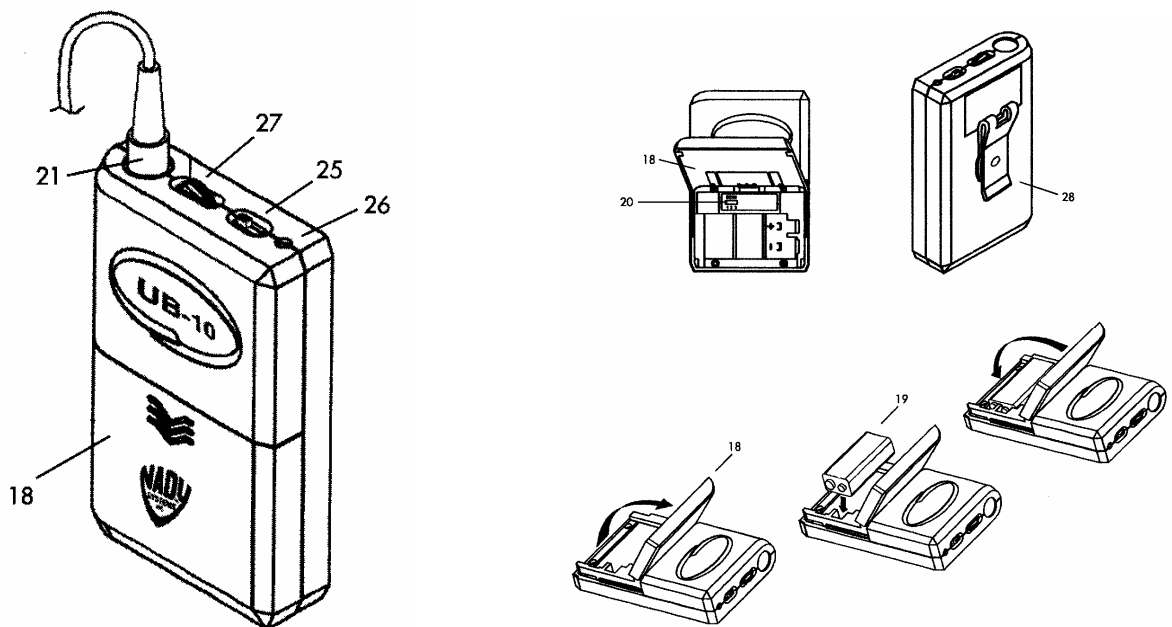

- 18. Battery Compartment
- 19. 9 V Alkaline Battery
- 20. Input Selector Switch ( Leave On 3 Lavalier)
- 21. 3.5 mm jack
- 25. Off/Standby/On switch
- 26. Battery Indicator LED
- 27. Volume- Input Level Control
- 28. Belt Clip

## How to Operate the Receiver (in Robot)

There are two adjustments on the receiver. The **volume** is on the back of the receiver, which you may set to the desired volume. On the UHF UB-10 you can change the volume on your belt transmitter *on the fly*. The other adjustment is the **sensitivity**. This is factory preset to maximum sensitivity. This effects how sensitive the receiver is to the transmitter signal. Typically you would never need to adjust this. The only exception would be if you get squelch when the transmitter is off. You can deal with this by simply turning on the belt transmitter whenever the robot is turned on. You could turn the sensitivity down slightly but turn the adjustment as little as possible, because adjusting it will affect the range.

### Function of the LEDs

**TX LED-** This indicates that you are receiving a signal from the transmitter. On some units it is a single TX light. On other units it may have an A or B that it will alternate between.

**AF LED-** This light indicates that audio is going through the receiver. It will flash as you speak into your headset mic.

**Tip:** For best range extend the receiver antenna(s) as much as possible, not allowing it to touch metal.

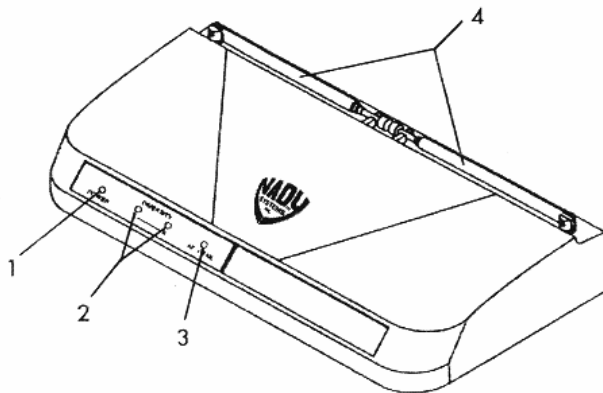

1. Power On LED Indicator
2. Diversity LED Indicators
3. AF Peak LED Indicator
4. Antennas
5. Power Switch (Leave On)
6. DC Input Jack
7. Frequency Label
8. Squelch Control
9. Aux. Volume Control
10. Audio Output
11. Balanced Mic. Audio Output XLR

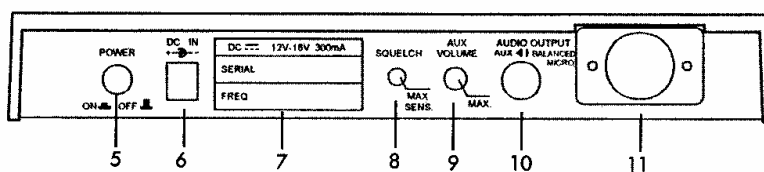

## How to Operate the 151 Transmitter (in Robot)

No adjustment is needed. The switches will be preset to on at the factory. It receives its power from the robot. No 9 Volt battery is needed.

### Function of the LED

When the robot is turned on, this light flashes and then goes out. This indicates that the transmitter is getting power.

## How to Operate the 151 Receiver (Operator)

1. Remove the battery door.
2. Use a 9-Volt alkaline battery and insert it according to the diagram in the battery compartment.
3. Plug the small round connector from the headset into the headphone jack on the top of the 151 receiver.
4. Turn the volume knob clockwise to the desired volume (if volume is too loud you will hear a loud high-pitched feedback noise. Turn the volume down until the feedback is gone.

### Function of LEDs

When turning the volume knob on with a fresh alkaline battery, the red light will blink on momentarily and go out. This indicates that it is powering up and that the battery has enough charge on it. As labeled, the light is a low battery indicator. When the light is on constant, this indicates that the battery is below 7 Volts. It then would need to be replaced.

**Tip:** The operator's voice units both have metal clips that contact the posts of the 9-Volt battery. These must be bent out from time to time to keep this contact good.

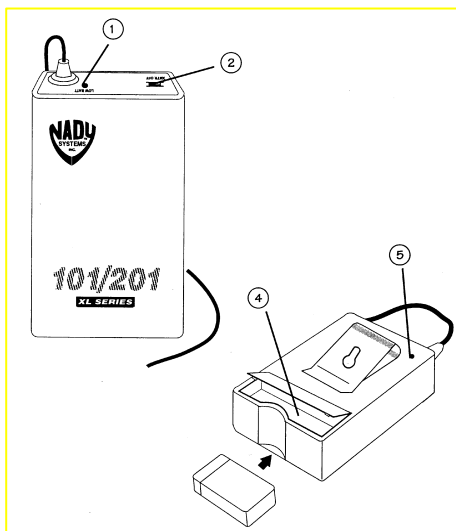

1. Low Battery Indicator
  2. Off/Mute/On Switch
  3. Antenna
  4. Battery Compartment (Not used)
  5. Audio Level Trim
- USE ALKALINE 9 VOLT BATTERIES**

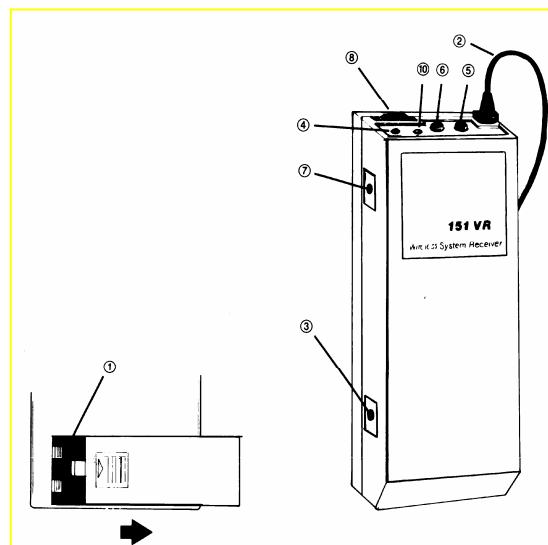

1. Battery door
2. Antenna
3. Mute control- Used if RF causes squelch. Leave Fully counter-clockwise for best range and reception.
4. Green TX LED- Indicates signal being received.
5. Headphones jack
6. Headphones jack
7. Volume On/Off
8. Volume On/Off
10. Low Battery LED- On steady means low battery



## **Warnings**

1. **Do not unplug or plug in the DC power plug on the robot receiver with the robot power on.** If the power is left on, the plug will short out and could damage the receiver. The fuse in line on the power wire that is plugged into this receiver may blow. This fuse is a round black fuse holder. If this fuse is not blown but no RX power light is on, check the audio fuse on the main fuse block in the electronics box.
2. Do not leave the voice units in direct sunlight or in a damp place for any length of time.
3. Remove batteries if voices will not be used for an extended period of time.
4. Keep voices and headset in the carrying case when not in use.
5. Generally when the robot is on, the operator's transmitter should be on. This will avoid the receiver on the robot picking up radio frequency interference and putting out static (see intermittent static problem of Voice System Troubleshooting).
6. Turn off the 151 receiver or remove the headset before turning off the robot. You can get a squelch in your headset when you turn off the robot.

## **Troubleshooting the Voice**

**For any voice problem, perform the following steps first:**

1. Check to see that the batteries are good in the operator's transmitter and in the 151 receiver. Normally when you turn the 151 receiver on, the low battery light should blink on and go off. When turning on the power switch of the transmitter, the light should blink on and go off. If either of these lights stays on constant, the 9-volt battery is too low and must be replaced.
2. Check that the battery is in the correct polarity and confirm that the battery contacts are making a solid connection to the spring clips inside the compartment. Bend them out slightly if necessary. If the battery is making intermittent contact in the Transmitter, try a different brand battery. Certain brand batteries are bigger than others.
3. Check all switch positions both on the operator and robot voice units. This includes the audio and the power switches. See the Voice Unit Diagrams for details about the correct position of these switches.
4. Check all plugs to and from the voices for proper connection.
5. Check the LED lights. When operating normally, the Receiver in the robot has a red TX light on. The UHF UB-10 Receiver has two LEDs, A and B to indicate that a signal is being received. The 151 Receiver has a green TX light. These lights indicate that a signal is being sent from the respective transmitter and that the receiver is receiving this signal.

**See the next page for specific problems and their solutions.**



Problem	Cause	Solution
<b>Voice System</b> <u>Always do the following first:</u> 1. Replace the 9 Volt batteries with new ones. <b>USE ALKALINE!</b> 2. Bend the battery contact out for better contact with the post of the 9 Volt battery. 3. Check power and audio switches, and lights on all voice units. 4. Check plug to and from the voices for proper connection. 5. Check if the transmit (TX) lights are coming on.		
Operator cannot talk	1. Low Battery. LED on steady or no LED flash.	1. Replace the 9 Volt battery. Is battery inserted in correct polarity?
	2. Battery posts not touching the metal clips in the operator's transmitter.	2. Bend out the metal clips. Put foam under clips.
	3. No power to the 101 Receiver. If yes, continue.	3. Check the in line fuse to the Receiver in robot and audio fuse on main fuse block.
	4. No TX light on the Receiver. If yes, continue.	4. Check Sensitivity adjustment on back of Receiver. It should be on Max. Sens.
	5. Audio wires going through pitch shifter connected wrong.	5. The wire should go from audio out of receiver to <b>input</b> of pitch shifter, then from <b>output A</b> into the main box and plug on to the main board.
	6. Headset plug to transmitter broken.	6. Take apart and look for broken wire or solder joint. TEST- Connect robot mic to transmitter. If it now works, problem is in headset. Repair or replace.
	7. Still not working. Call Robotronics.	Send transmitter, receiver, and headset in.
Operator cannot hear	1. Low Battery. LED on steady or no LED flash.	1. Replace the 9 Volt battery.
	2. Battery posts not touching the metal clips in the operator's receiver	2. Bend out the metal clips. Put foam under clips.
	3. Headset plug to 151 RX has a broken wire.	3. Unscrew cover of plug and look for broken wire.
	4. Robot 151 transmitter not turned on.	4. Turn on audio and power.
	5. Power plug to robot 151 transmitter unplugged.	5. Find wire and plug it back in.
	6. If you have no TX light on 151 RX mute could be out of adjustment	6. Adjust the mute on the 151 RX to max. which is fully CCW.
	7. Robot microphone in robot is bad.	7. Order a replacement. TEST- Plug your headset into the robot transmitter in place of the robot microphone and test.
	8. Still not working. Call Robotronics.	8. Send robot mic, transmitter, receiver, and headset.
Voice Operates but cuts out. Should get 50 feet without any cutouts.	1. Low Battery.	1. Replace the 9 Volt battery.
	2. Sensitivity Adjustment down too far.	2. Sensitivity adjustments should be at max. on the 151 Receiver and robot receiver.
	3. Broken, loose or retracted antenna	3. Extend robot receiver antenna or replace broken antenna.
Squelch coming from robot	1. No signal being sent to the robot	1. Turn on the operator's transmitter.
	2. Sensitivity is too sensitive.	2. Very slightly adjust sensitivity down from max. (This will decrease your range)
Squelch in headset when turning robot off.	1. 151 Receiver slightly too sensitive.	1. Adjust 151 RX mute slightly CW
	2. 151 RX picking up interference in your area.	2. Always turn off 151 RX and remove headset before you turn off robot.

## D

### CASSETTE TAPE PLAYER SYSTEM

The tape player is located on the inside of the back cover.

#### How to Play A Cassette Tape

1. Insert a regular type cassette tape into the player.
2. Depress the play button on the cassette player.
3. Move the radio tape select switch to the tape position.
4. Activate the tape player from the Pushbutton control.
5. The tape player volume can be adjusted on the tape player or on the master volume of the audio control module. The tape player volume also changes when you select volume high or volume low on the pushbutton control.

#### Tape Tips

After you play a cassette tape several times, the tape might become tightly wound on the reels. This can cause playback sound quality to deteriorate. To restore the sound quality, fast-forward the tape from the beginning to the end of one side, then completely rewind it. Then loosen the tape reels by gently tapping each side of the cassette's outer heel on a flat surface.

#### Maintenance

Always remove the cassette tape when not in use. This will prevent flat spots on the capstan roller. The tape head of the cassette player should be cleaned and demagnetized after every 20 hours of use.

To clean the tape handling parts:

1. Remove the power connector.
2. Pull open the cassette compartment door and remove the tape. Set to tape mode.
3. Press play to expose the tape head.
4. Use a cotton swab dipped in tape head-cleaning solution or denatured alcohol to gently clean the capstans, tape guides, pinch rollers, and tape head.
5. When you finish cleaning, press stop and close the compartment, then reconnect the power wire.

### Troubleshooting Cassette Player

#### No operation when you activate the tape function:

1. Is the cassette fully inserted ,play switch pushed, and the volume level up.
2. Is the cassette unit receiving power?  
If not, make sure that the mode switch on the cassette player is in tape mode.  
If it is still not working check the **wiring, plugs and the audio fuse** on the fuse block.  
(See the Chair Fuse Block Detail)
3. Is the Radio Control Transmitter "ON" and working? Listen for the cassette motor and check to see if the power light or FM stereo light is on as the R.C. is activated.

#### Sound Quality is poor:

1. Test the cassette tape on some other player. If the cassette tape is OK, clean player and try again.
2. If the tape is running slow, loosen the tape by spinning it with a pencil. Try a different tape. The tape running slow may be an indication of worn out belts that need to be replaced or the cassette player needs to be replaced.

## **E** **SIREN**

The robot siren is operated by remote control from the Radio Control Transmitter. The siren circuitry is located on the main circuit board. See the robot main circuit board diagram, in the Appendix, for the siren volume, mode select and oscillation frequency. The volume of the siren is controlled by a trim pot on the main board. Turning the pot clockwise will increase the volume of the siren. Turn the pot counterclockwise to decrease volume. Three different sirens are available. Choose the siren you want by moving the jumper located on the siren mode select. To control the oscillating speed, adjust the siren frequency trim pot in the siren circuit. The siren mode select is set to the common siren for your robot. If the siren mode select is changed, the siren frequency will very likely need to be adjusted.

### **Trouble-Shooting**

1. Check if the audio booster is working by testing the voice or activating the cassette player. If it is not, check the audio fuse on the fuse block in the main electronics box. Also check the speaker connections at the speakers as well as the 5-pin speaker connector located just forward from the main electronics box.
2. Call the Robotronics' Service Department for assistance.

## F

### DRIVE MOTOR SYSTEM

Your robot is provided with two high quality industrial grade drive motors. Each motor controls a drive wheel-left and right. Steering of the robot is accomplished by varying the speed and direction of these motors. For example, when the left motor runs faster than the right, the robot turns to the right.

Each drive motor is connected to its drive wheel via pulleys and 1/2" wide rubber timing belts. The pulley set screws and bolts should be kept tight.

#### Trouble-Shooting - Drive

Perform the following steps first when trouble-shooting a drive problem:

1. **Check drive belts and motor pulley set screws.** Especially if you hear the motors activate but the robot does not move.
2. **Check connections to motor controls and motor leads.** These are blue and yellow wires coming from the electronics box and going to the drive motors. There is a white connector in line. The joystick could be pushed in the on position while the connector is being checked for an intermittent connection. If there is a bad connection, the connector and/or pins should be replaced. While doing the test just explained, have the robot wheels off the ground.

---

**Note:** The best way to look at what the drive motors and wheels are doing is to put something under the back of the robot to get the wheels off the ground. You will then be able to see exactly what motor and wheel is working or not working, and in what direction.

---

**Neither drive operates:** Check both fuses in the fuse block. Check set screws on the motor pulleys.

**One drive motor does not operate either direction:** Check the specific drive fuse on the fuse block (left or right). See the fuse block detail to identify the correct fuse, or look for any blown fuses. The fuse block is located in the main electronics box. If after replacing, the fuse blows again, the **drive motor** or **drive circuit** could be causing the problem.

**Drive motor-** If the drive motor is the problem, you would have likely heard the motor grinding or scraping before the fuse blew. To test the motor for operation, swap the motor wires. It is best to have the robot wheels off the ground when doing this test, in order to see which wheel is operating. The motor wires are blue/yellow wires hanging down below the electronics box. You may have to remove the robot battery, to make the swap. If now the wheel/motor on the side in question operates and sounds fine then the motor is good.

**Drive circuit-(motor control)** If the drive motor is good, the drive circuit (motor control) could be the cause of the fuse blowing. If this is the case, check for broken or shorted wires and if nothing is found, contact the Robotronics' service department for assistance.

**One drive motor operates only in one direction:** The motor control circuit is likely the cause of this. The problem is in the drive circuit. Send the main electronics to Robotronics for repair or contact our Service Department.

**The robot is not driving straight:** (Veering when you drive)

**Note:** Before making this adjustment, be sure that your motor pulley set screws are tight and that both motors appear to be working forward and reverse. To check this prop the back of the robot off the ground.

To locate the adjustment, see the Robot Main Electronics Box diagram in the Appendix. They are labeled **Forward Drive adjust** and **Reverse Drive adjust**. You will need a small flat head precision screwdriver to make the adjustment. The cover of the main electronics box would need to be removed to access the adjustment. Take the cover of the box completely off and set outside the robot so that it cannot touch the post(s) of the robot battery.

Forward Drive Adjust Pot- Effects forward straightness of drive.

Robot veering left- Adjust it counter-clockwise

Robot veering right- Adjust it clockwise

Reverse Drive Adjust Pot- Effects reverse straightness of drive.

Robot veering left- Adjust it counter-clockwise

Robot veering right- Adjust it clockwise

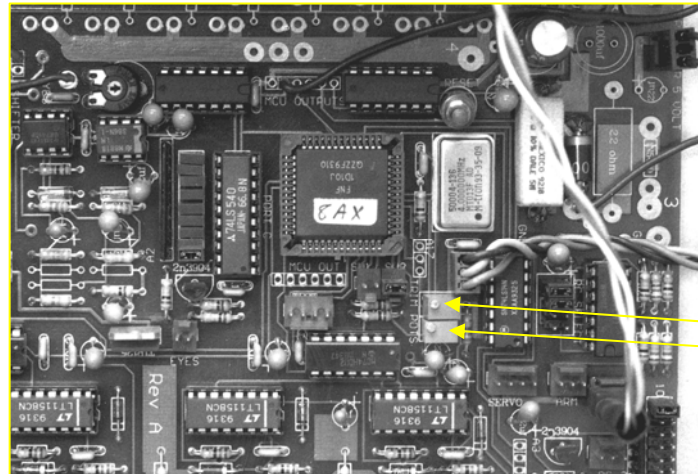

Drive Straightness  
Adjustments:  
**Forward**  
**Reverse**

If the robot veers, the reason is that one motor is going faster than the other at any given position of the joystick. For example if at full speed, the robot veers to the right, this means that the left motor is going faster than the right motor. To correct this you would adjust the forward drive adjust pot clockwise. You may need to do some trial and error to get it just right. To do this, adjust the necessary adjustment pot very slightly and then drive the robot to see if the robot is driving straighter. Continue the adjustment until it drives suitably for you. It is best to use full speed during the adjusting, because this will act as a good reference point.

### **The robot is moving slightly even though the drive stick is at neutral:**

Move the sliders next to the drive stick until the robot neutrals out. This is called trimming the stick.

- Contact the Robotronics' Service Department if you need any assistance or parts.

## G

### ARMS AND HANDS MOTOR SYSTEM

The arms are operated by two motors, and two additional motors are used to operate the hands. The arm motors can be seen in the diagram in the Appendix; Inside Front View. An inside view of the arm can be found in the Appendix. The arms are easily removed if needed. The arm center bolt at the shoulder must be removed and then the arm can be taken off.

The hands are operated with a motor that is located inside the arm. A cable pulls the hand open and closed. If the hand has been moved out of position, the distance that the hands open or close may change. If this happens loosen the screw that clamps the cable down. Open the hands via the RC and readjust the hand position. Tighten the cable clamp screw.

#### Trouble-shooting

##### One Arm does not operate.

Check the wires leading from that motor down to the main electronics box. Especially check at the in line white connector. Look for a broken wire or one that has come out of a connector.

##### Both Arms do not operate.

Check the fuse on the main fuse block, which is for power to the arms board.

##### An arm is in the wrong position.

Move the lever on the control unit that raises and lowers the arm. Put it in the arm down position. If the arm is not in the arm down position, check the arm feedback pot (See the Appendix; Inside Front View). Check the tightness of the setscrew. If it is loose, tighten it and call Robotronics for help getting the arm back in position.

If this is tight, check the feedback pot wires for a broken wire or one that has come out of a in-line connector.

##### A hand is not working.

Check the wires that go through the shoulder plastic and out to the hand servo-motor. Look for a broken wire. In the robot, follow the wires to the eyes and hands circuit board and make sure that the wires are securely connected. Check for a broken wire to the switch on the RC transmitter.

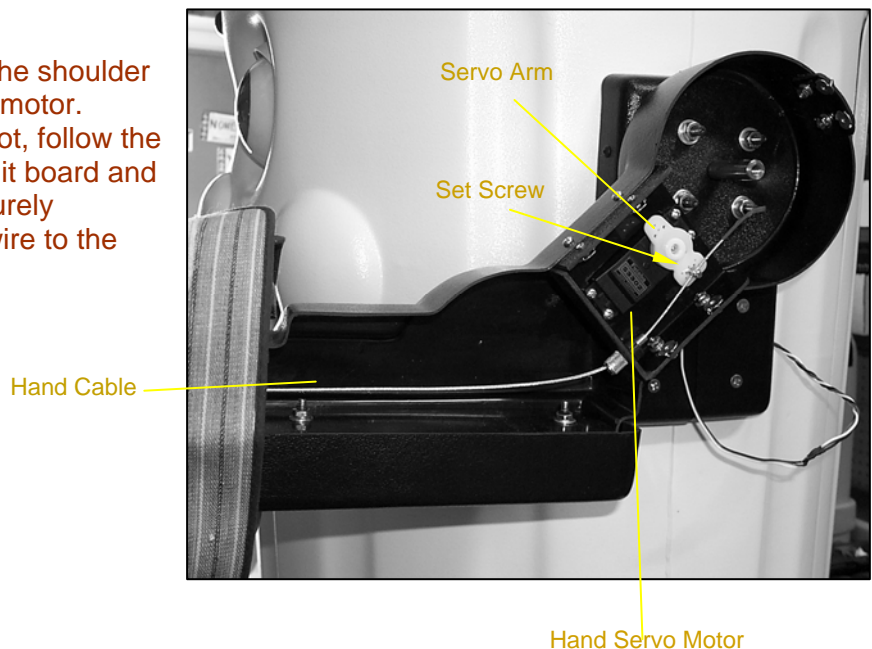

## **H**

### **EYELIDS AND EYES LEFT AND RIGHT**

The eyelid and eyes left and right movement is accomplished by three servo motors. When the switch on the radio control is activated, this signal is sent to the radio control receiver in the robot. The microprocessor in the robot encodes this signal and a new signal is sent to the eyes and hands servo board. The eyes and hands servo board is located on the mouth board directly behind the mouth itself. On some models it is located on the plastic brace running above the main electronics box. To see it, the dome would need to be removed or see the diagram in the Appendix; Inside Front View. The wires connected to this board take the signal to the servo itself and operate the shaft of the servo motor to turn clockwise or counter-clockwise for opening or closing. The rotation of the servo motor shaft is coupled to the eyelid and pupil eye slide plate with a servo arm and then a eyelid rod.

#### **Trouble-Shooting**

##### **An eyelid or the eyes left and right does not operate:**

1. Check the linkage from the servo motor. Look for the servo arm off the servo shaft or the eyelid off the ball link.
2. Follow the wires from the specific servo motor with the problem. The wire will run to the eye servo board. If it is disconnected, reconnect according to the eye servo board diagram. If the servo does not work correctly (wrong direction), try one of the other outputs on the eye servo board.
3. If the servo wire is connected to the eye servo board, look at the wires coming off the other side of the board to make sure that none are broken. These wires go down to the large round connector and into the main electronics box. Examine the wires at the connection on the main circuit board in the box.

##### **One of the eyelids is at a different level than the other:**

1. If the eyelid rod is bent, bend it back into position.
2. If the servo saver arm (white and metal arm interconnecting the servo and the rod), is solid and secure the position of the eyelid can be positioned to match the other eyelid. To remove the servo saver arm, the set screw must be removed. The eyelid level can be changed by altering the length of the eyelid rod or changing the position of the servo saver arm on the servo motor shaft.

##### **There is no operation of any of the eye functions:**

1. Check the wires running from the eye servo board down to the large round connector. Did the wire come off the eye servo board? Reconnect.
2. Look at the wires in the main electronics box where the eye wires connect to the main circuit board.

# I SPECIAL FEATURES

The special features of Curby the Recycling Robot are the following:

- I. Lifting and lowering lid
- II. Flashing Mouth Lights

## I. Lifting and lowering lid

The lid is operated by the left joystick forward and back movement. Movement of this stick sends a signal to the receiver in the robot which signal is processed by the microcontroller and then a signal is sent to the lid and wrist movement board which sends power to the lids linear actuator.

## IV. Mouth Flashing Lights

The mouth flashing lights flash in response to the operator speaking into the headset, with the loudness or softness of your voice effecting the number of mouth lights that turn on and the intensity that they turn on.

---

**Note:** When the robot battery begins to go low, some of the lights will not light as consistently.

---

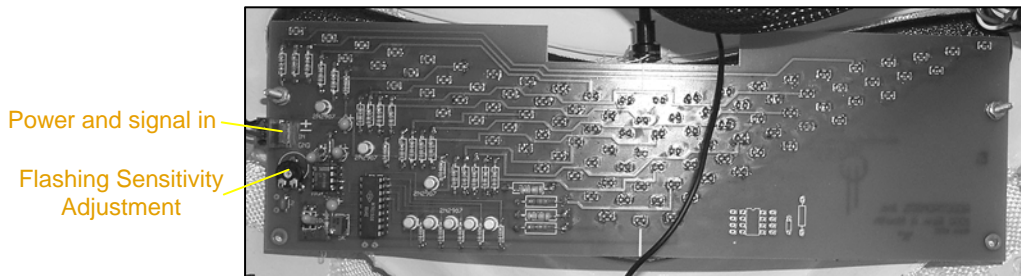

## Trouble-Shooting

### Lid Operation

- No operation- Check the wiring and connectors.
- Slow operation- Charge the robot battery or replace it.
- Motor sound but no movement- Check the linkage inside and out.

### Mouth Flashing Lights

If there are no lights, first make sure that your robot battery is fully charged. Next check the power wire (red and black) to the mouth circuit which is located directly behind the mouth (Diagram; Inside Front View). If it is disconnected, connect it according to the diagram or contact Robotronics' Service Department for help.

If you have lights but they do not trigger to the voice, check the wire directly below the power wire. This should be a purple wire and is the mouth trigger.



## Voice Modifier (Pitch Shifter) Instructions

The pitch shifter (voice modifier) can change the operator's voice to disguise it and create a robot character type voice. The operator's voice signal is received like normal by the voice receiver in the robot. The signal is then sent from the audio out of the receiver to the **Input Jack** of the pitch shifter. It is modified and sent from the shifter **Output A** to the voice 'audio in' on the main circuit board.

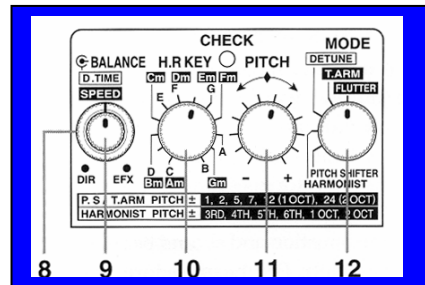
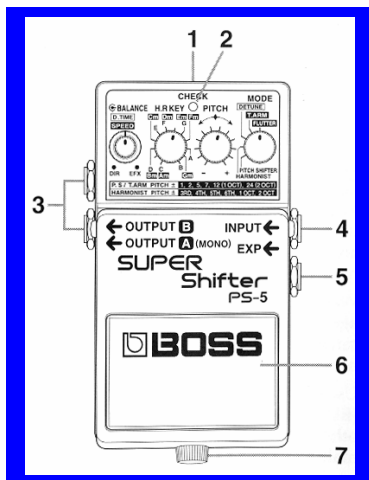

1. Power Jack – 9 Volts center negative
2. Check indicator – Power indicator and show whether an effect is on or off.
3. Output Jacks. Output A is what we us.
4. Input Jack.
5. EXP Jack. No used.
6. Pedal Switch. Turns it on or off.
7. Thumbscrew. To release pedal.
8. D.Time Speed Knob – Delay time. Not used in pitch shifter or harmonist mode.
9. Balance knob – This adjust the output balance between the direct sound and the effect sound. Typically set this on EFX for the full effect.
10. H.R. Key switch. Not used.
11. Pitch Switch. Adjusts the amount of pitch shift.
12. Mode Switch. Selects the mode. Typically use the pitch shifter mode.

The pedal on the pitch shifter is used to turn it on and off. When the pitch shifter is on, the power light labeled 'check' will be lit. The shifter will take a few seconds to power up. To turn it off, push the pedal again. If the pitch shifter is not turned on, your unmodified voice will come through the Smoke Alarm.

The pitch shifter has two basic effects; a digital pitch shifter and a delay. There are many variations of these two effects. When used as a pitch shifter, you can vary the shift within +/- 2 octaves. Set the mode knob to Pitch shifter and then vary the pitch knob until you get the sound of voice that you want. You can get a similar effect with the harmonist position but the pitch shifter gives you the best sound. These are the most common modes used because these modes give you the ability to adjust the shift of your voice to exactly what you want whether up or down. About 2:00 on the pitch knob gives you a good voice.

The shifter gets power from the robot battery; no internal battery is needed. If the cover of the main electronics box ever needs to be removed, do not allow the shifter power wire plug, to contact the metal box. The metal box surface has a ground connection. The fuse related to the shifter is the audio fuse located on the fuse block.

Below is a typical setting for the robot voice. This will give you a shifted cartoon character or robot type voice.

Balance-clockwise  
Pitch-About 2:00  
Mode-pitch shifter

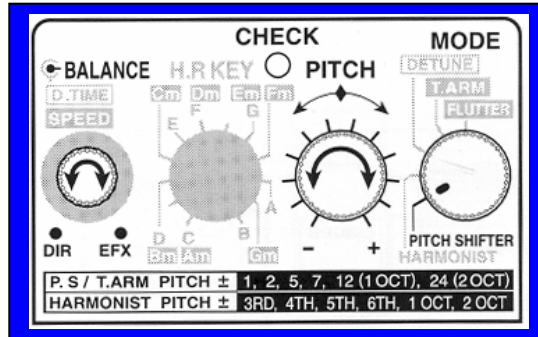

# K

## Water Squirter Instructions

### WATER SQUIRTER SYSTEM

The new system has a reservoir in the robot that you remove to refill. It is held by an elastic band. It does not need the refill switch or an overflow nozzle. This saves time and gives you a larger reservoir.

#### **Fill the Water Bottle**

Remove the water bottle inside the rear of the robot by disconnecting the tube from the water connector. Push on the metal clip to release it. Fill with water and replace. Make sure you have the elastic around the bottle when you put it back in.

#### **Squirt Water**

Just hit the switch on the control to squirt.

#### **Water Squirter parts and where to find them**

**Water bottle** - Comes with the robot inside the rear door.

**Water squirter nozzle** - Typically located in the front of the lower robot.

**Female water connector out to nozzle** – Inside rear door.

**Female water connector from water bottle** – Inside rear door.

**Water pump** - Located on the left side behind the water bottle.



#### **CAUTION**

The water squirter system should not be operated without water in it.

The parts of the water squirter are shown on the next page.

# Water Squirter Parts

## Rear Inside View

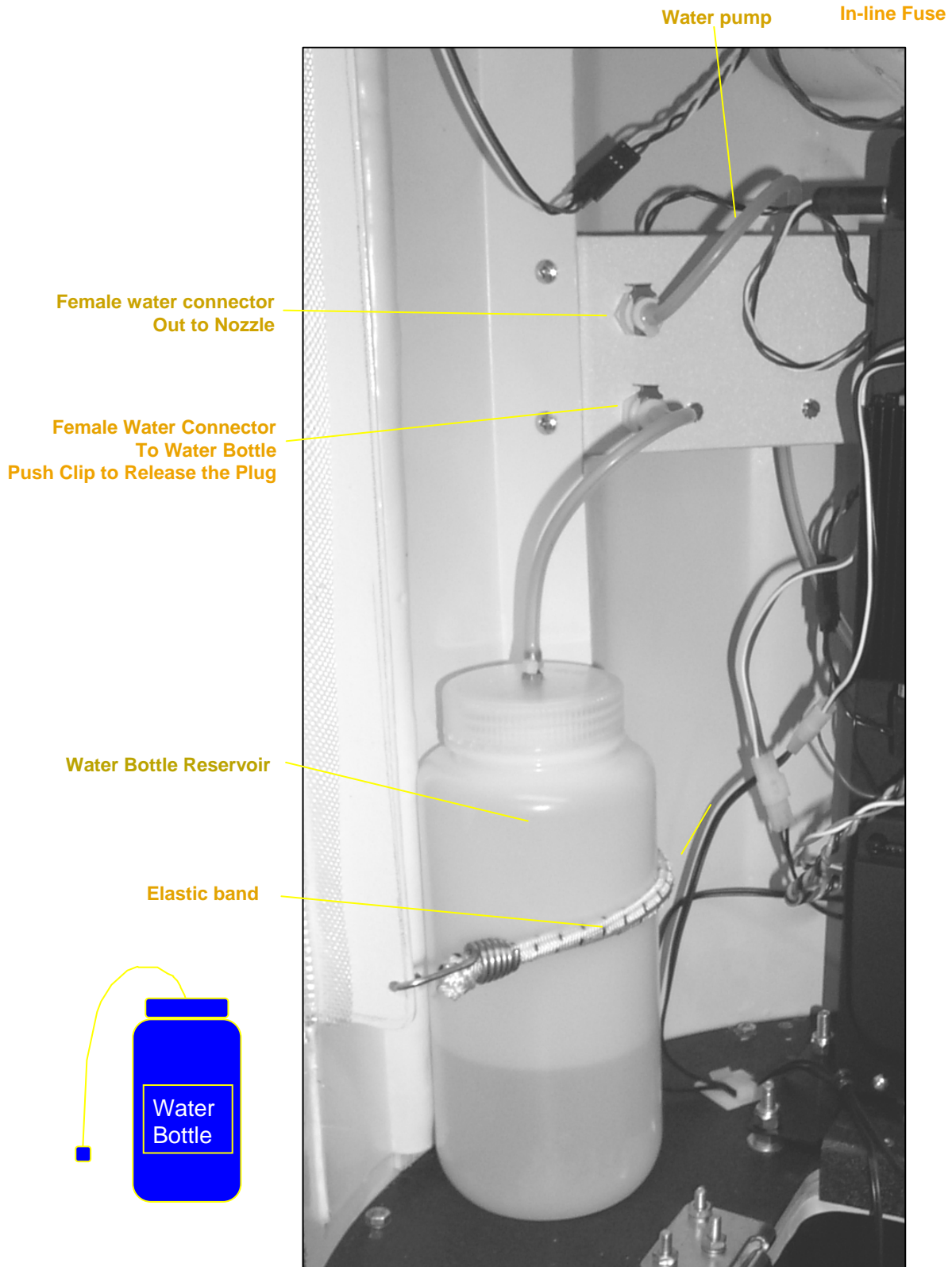

## Helpful Hints and Cautions:

1. The water pump should not operated very long without water in the reservoir or the pump will could wear out faster.
2. Always make sure the water lines are connected properly when using the water squirter or water may damage the electronics.

## Trouble Shooting

Problem	Possible Cause	Solution
<b>Water Squirter System</b>		
Cannot squirt; no pump sound.	a. Pump bad. Check for Voltage at pump. b. Broken wire at pump.	a. Replace the pump. b. Repair broken wire.
Cannot squirt; pump sound-yes.	a. Reservoir empty. b. Nozzle water line is not connected to water connector. Tube popped off. c. Nozzle or tube plugged	a. Fill water bottle. b. Connect it. c.Remove the nozzle and clean out. Blow air through tubing and nozzle.

If you have any questions, contact the Robotronics Service Dept. at 801-489-4466.

## Part 3 Assembly & Disassembly

### Removing the lid

1. Lift the lid so that you can reach the two thumbscrews inside. Loosen these as much as you can.
2. Disconnect the blue and yellow wire connection going to the lifting actuator.
3. The entire lid and lifting mechanism comes out in one piece.

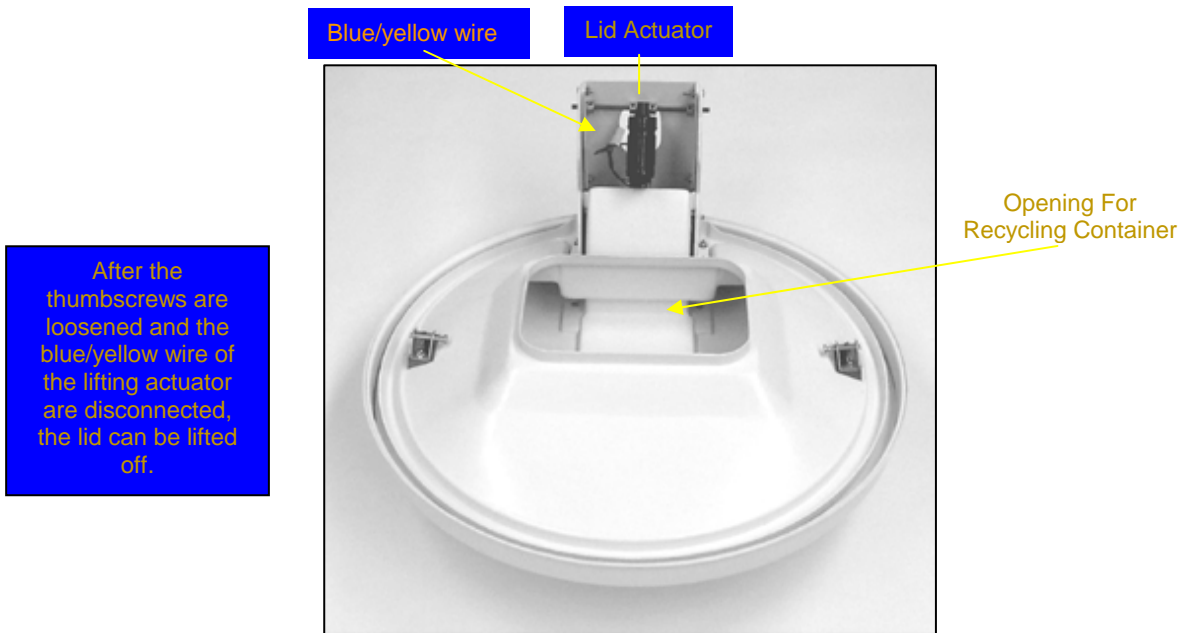

### Removing the Arms:

1. Disconnect the wires going to the hands at the in line connector.
2. Use a 7/16" socket and remove the 1/4 bolt.
3. Remove the arm by pulling out on the arm.

### Removing the Drive Base:

1. Unplug and remove the battery.
2. Unplug the motor power wires.
3. Lift and turn the wing on the left and right link lock latches.
4. Lift up on the body and set it aside. The drive base will remain.

Perform assembly in reverse order.

## Part 4 Maintenance

### Inspection

Periodically the robot should receive a thorough inspection.

1. Examine the exterior of the robot and make repairs as necessary.
2. Check all bolts and nuts for tightness. Especially make sure the drive motor pulley set screws are tight.
3. Examine electrical wiring and connectors for looseness and wear.
4. Lubricate the drive wheel axles with grease (optional) and inspect the drive belt and pulley system. Be careful not to get grease on the drive belts.
5. Clean the cassette tape system according to instructions about the cassette player.
6. Wash the robot body with mild soap and water and a soft cloth and reattach body. (Rubbing alcohol may be used on stains that won't come off with soap. If this causes the finish of the plastic to become dull, apply ARMOR-ALL brand protectant.
7. Check Radio Control System and Voice Transceiver for broken wires, (Check the controls, cases, all fasteners etc.)
8. Fully charge the battery and test all robot system functions.  
To prolong the life of your robot system, always store in a safe place away from moisture and excessive heat. Put a dark robot cover over it to keep the ultra-violet light and dust off. The robot and Radio Control Transmitter batteries should be stored fully charged. Store the robot standing up.

### Recommended Tool Kit

Fuses- 1,3,5,15,20,30 Amp (AGC type)  
4" cable ties  
Small regular and Phillips screw driver  
Precision flat head and Phillips screwdrivers  
Needle nose pliers  
Socket set with ratchet  
Wrench set  
Set of Allen wrenches (Especially 3/32",5/32",1/8" and 1/4")  
Extra 9 Volt alkaline battery  
Small soldering iron and solder  
Digital Multi-meter (Volts/Ohms)

## **PAINTING OF THE ROBOT BODY**

The following information are only suggestions of painting methods. Contact a professional for assistance.

### **Preparing the surface:**

The robot body is an ABS plastic and should be cleaned before painting to remove oils and dirt. This is especially true if the surface has had a protectorant such as Armor-All put on it.

If the body has not had a protectorant or other silicone product used on it, you could clean the area with isopropyl alcohol to prepare it. It helps to smooth the rough edges of the scrapes or scratches before painting with a 600 grit sandpaper. You can lightly sand the area to paint with the 600 grit sandpaper or a Scotch-Brite 7448 pad.

### **Painting the surface:**

#### **Method 1**

Enamel spray paints such as Krylon Interior/Exterior enamel could be used. This can be touched up easy if the paint ever got a scuff or scrape but is typically just for painting trim, bumpers, gauge plates etc. Carefully cover parts that are not to be painted with masking tape and paper, to protect against over spray.

#### **Method 2**

Note: If you use method 2, you should contact a professional painter that has had experience painting on various types of surfaces. These are automotive type paints and typically include a primer and base coat. For a glossy look you can use a glossy base coat or a clear coat.

#### ***Brand- Dupont***

Primer: Acrylic Urethane Flexible Primer Surfacer. One brand: mar-hyde (Talsol Corporation). Other brand: 5 Star Auto body Products Maximum 2K(5404) Use with activator (5406).

For additional flexibility: Can use Dupont Plas-stick Flex Additive(2350S) with the primer.

Paint: Acrylic Enamel. Dupont ChromaBase Basecoat.

#### ***Brand- PPG***

Primer: Check with painter.

Paint: Deltron DBU

#### ***Brand- Sikkens***

Primer: Plastoflex primer by Sikkens

Paint: Autocryl by Sikkens (two-part acrylic urethane enamel)

The information listed includes suggestions and general information. This material is designed for application only by trained professional painters using proper equipment.

If you have any questions, call our service department at 801-489-4466.



## REPAIR OF THE ROBOT BODY

### Materials

Super glue

ABS or PVC clear medium bodied glue

Fiberglass mesh

rubber gloves

1. Seal the crack with the super glue by running a bead of glue on the inside of the body. Do not allow the super glue to run on the outside of the body, because it could etch into the plastic. Hold the two pieces of plastic together at the seam until the super glue dries. This will make the seam look better. The purpose of the super glue is to hold the seam together until the mesh and PVC glue are applied, and to keep the PVC glue from leaking through the seam/crack on to the body. Check the seam to make sure it is sealed tightly. If necessary, apply some more super glue.  
\* To hold the plastic together during drying masking tape inside the body could be used.
2. If there are pieces of plastic reinforcement across the seam that are unglued, PVC or ABS glue can be used between the reinforcement piece and the body. A clamp could be used to hold the plastic tightly together while drying.
3. Cut a piece of fiberglass mesh to cover the crack.
4. Position the body, so that the seam/crack is horizontal to the table .(Inside of the body.) This will keep the glue from running. Apply some of the PVC or ABS glue along the seam/crack, only on the inside of the body. Check to make sure that the glue is not running through the crack on to the outside of the body. This would etch into the plastic. Note: Avoid getting the glue on your hands.
5. Immediately put the fiberglass mesh on the glue and pat it down to saturate into the glue.
6. Apply some more PVC or ABS glue over the fiberglass mesh to saturate it some more.
7. It will dry to the touch in about 30 minutes. Allow 24 hours for complete drying.

### General Precautions:

Use in a well ventilated area.

Use gloves to avoid getting glue on your hands.

Avoid getting the fiberglass on your skin or clothing, as it may cause skin irritation.

For further precautions, read the super glue and PVC or ABS glue labels.

## STORAGE

Storing your robot for any length of time.



1. Remove robot battery and charge fully as per instructions in battery section. Also fully charge the Battery on the belt pack. These are both Gel Cell batteries. **Storing the battery for any length of time without being fully charged will permanently damage the battery.**
2. Discharge the RC and Super RC battery and Fully charge it. It is discharged enough if the needle is anywhere in the red. These batteries are NiCd type.
3. Remove batteries from operator's voice transmitter and receiver.
4. The RC Transmitter and voice pieces should always be stored in the carrying case. This will extend the life and help insure proper operation.
5. Inspect robot for loose bolts or any additional maintenance that may need to be done.
6. Clean the body thoroughly. (If robot is stored with a dirty body it may be harder to clean at a later date, as stains may become permanent.)
7. Storing your robot with a dark dust cover (robot cover) on it will keep the robot clean and protect the body from scratches and the effects of ultra-violet light. If you do not have a robot cover, use dark plastic bags.
8. The robot and batteries should be stored in a dry place between 55-75 degrees F. Storing the robot in a safe place will prevent scratches and extend the life.
9. After storing the robot for any length of time, always test the robot well in advance of any scheduled activity as it is impossible to anticipate problems. This will ensure time to correct the problem.

# Appendix

# Robot Circuit Diagram

## Robot Circuit Diagram

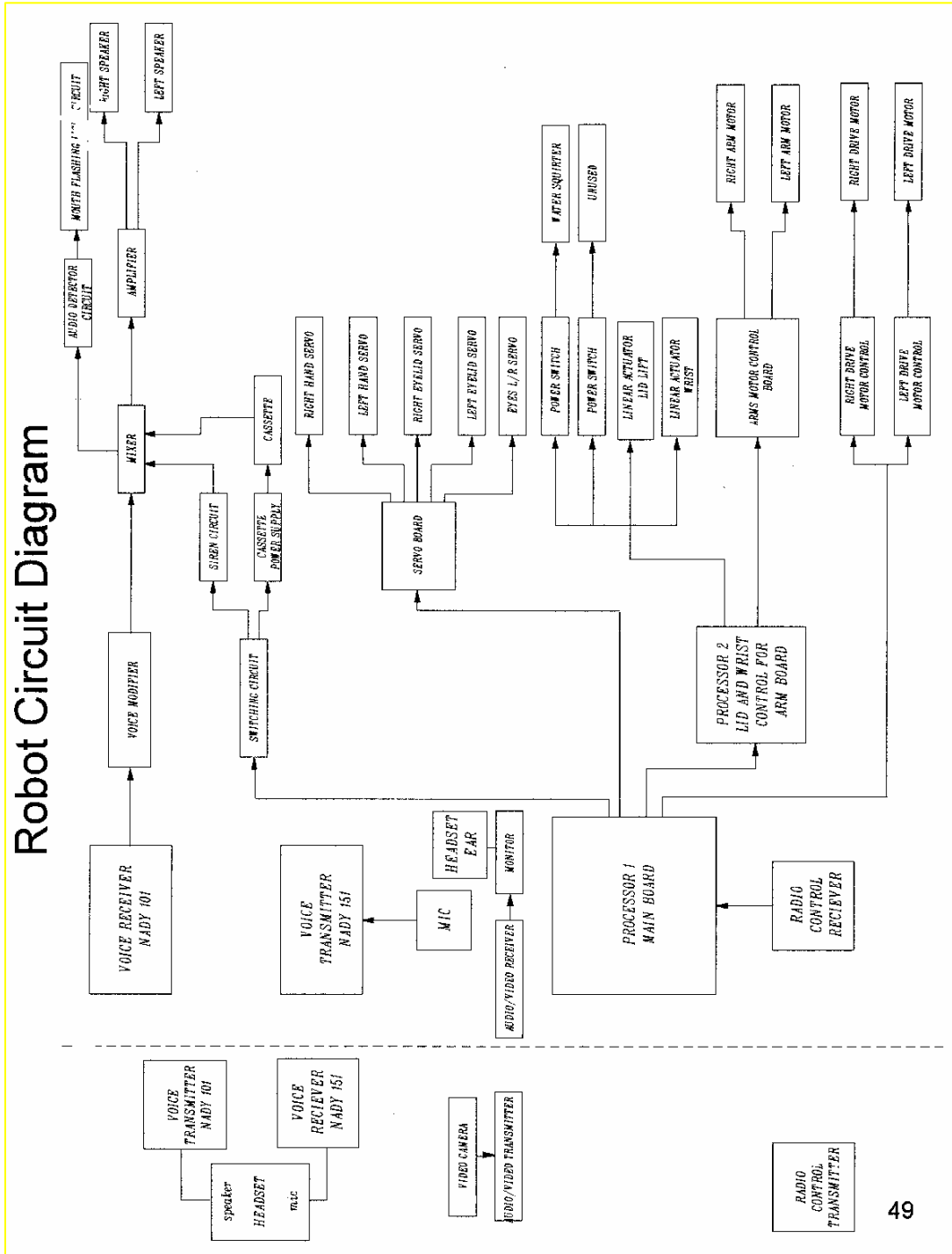

# Robot Parts Identification

# Inside View (From Back)

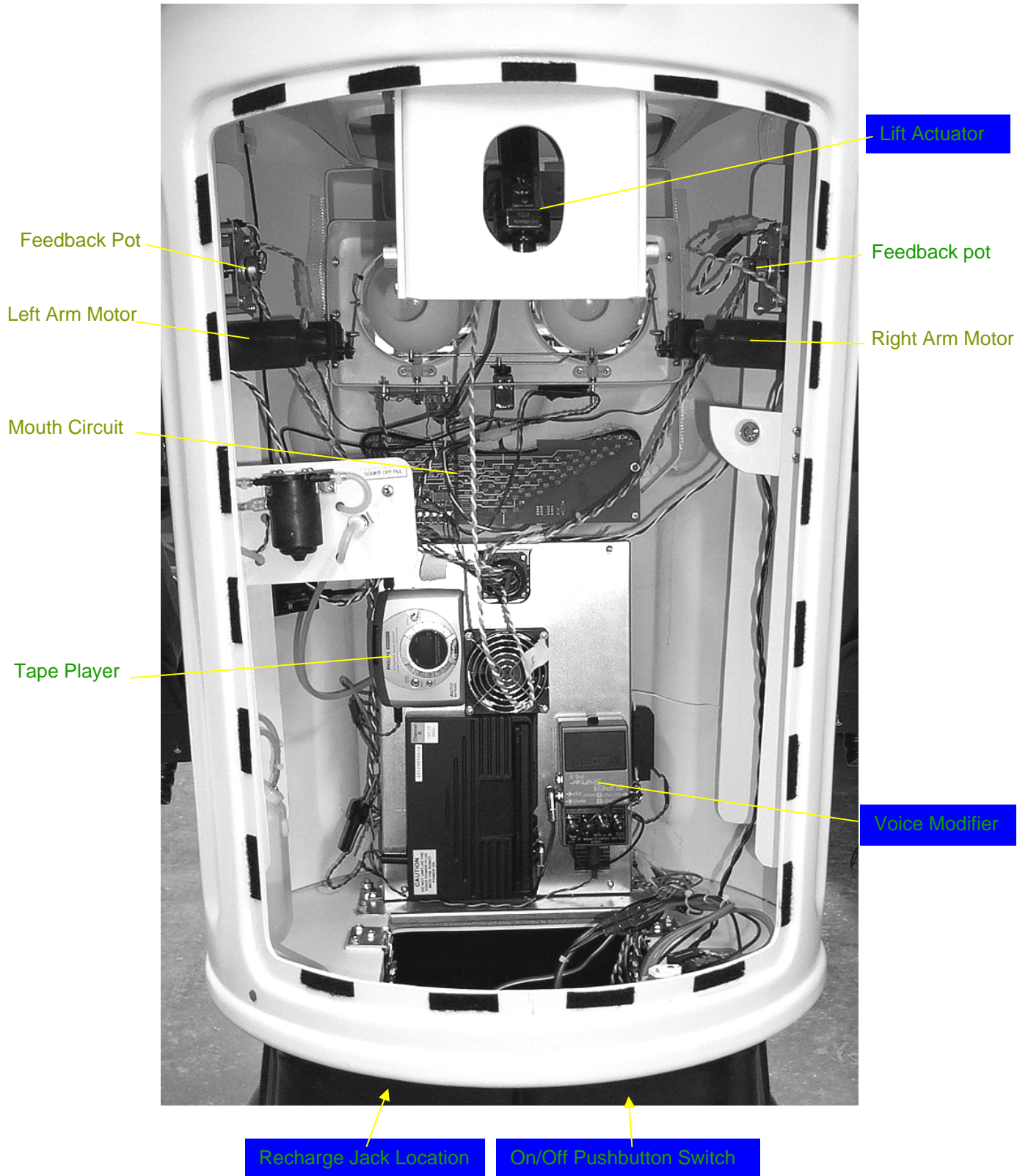

# Main Electronics Board

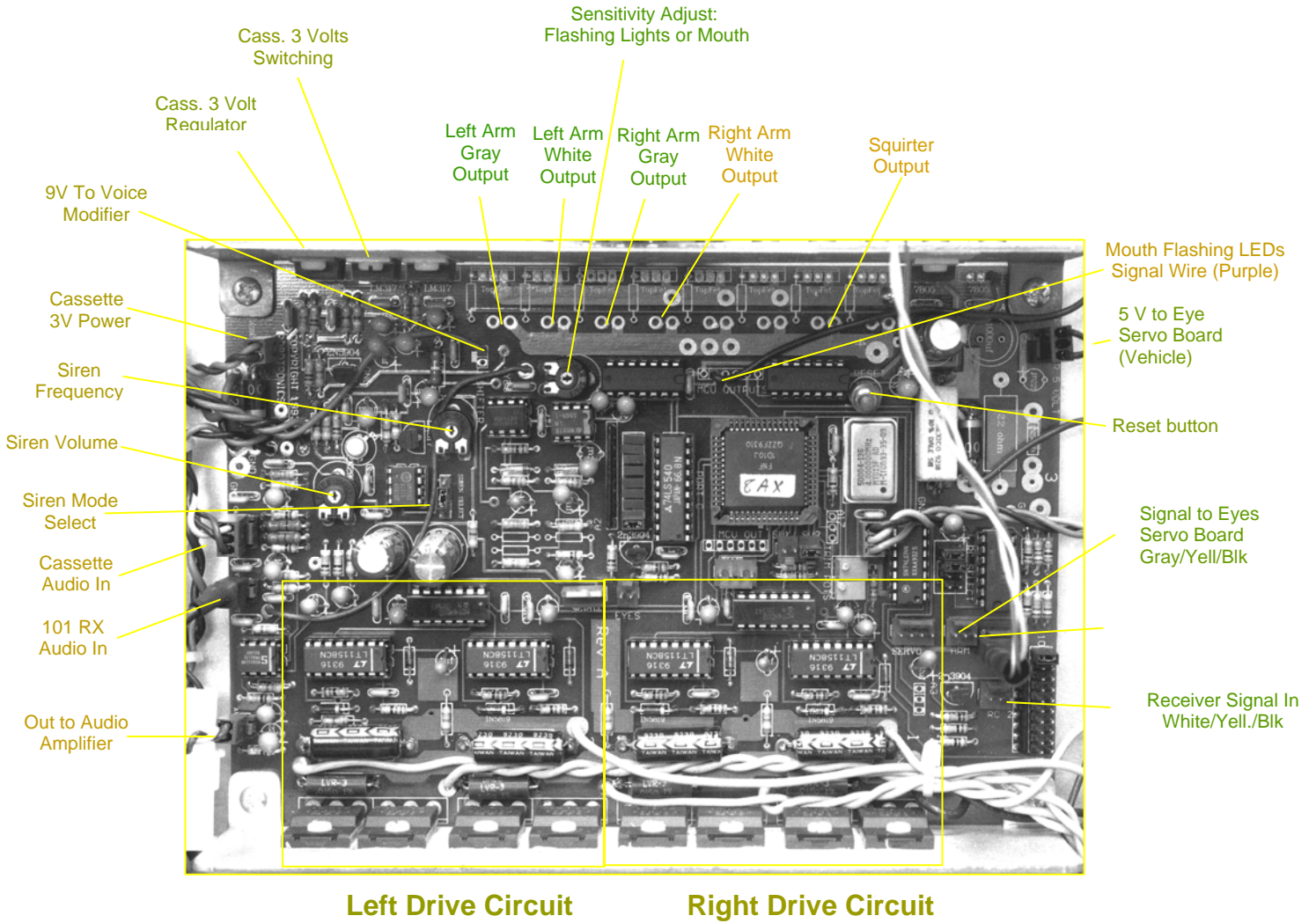

# Main Electronics Panel Inside

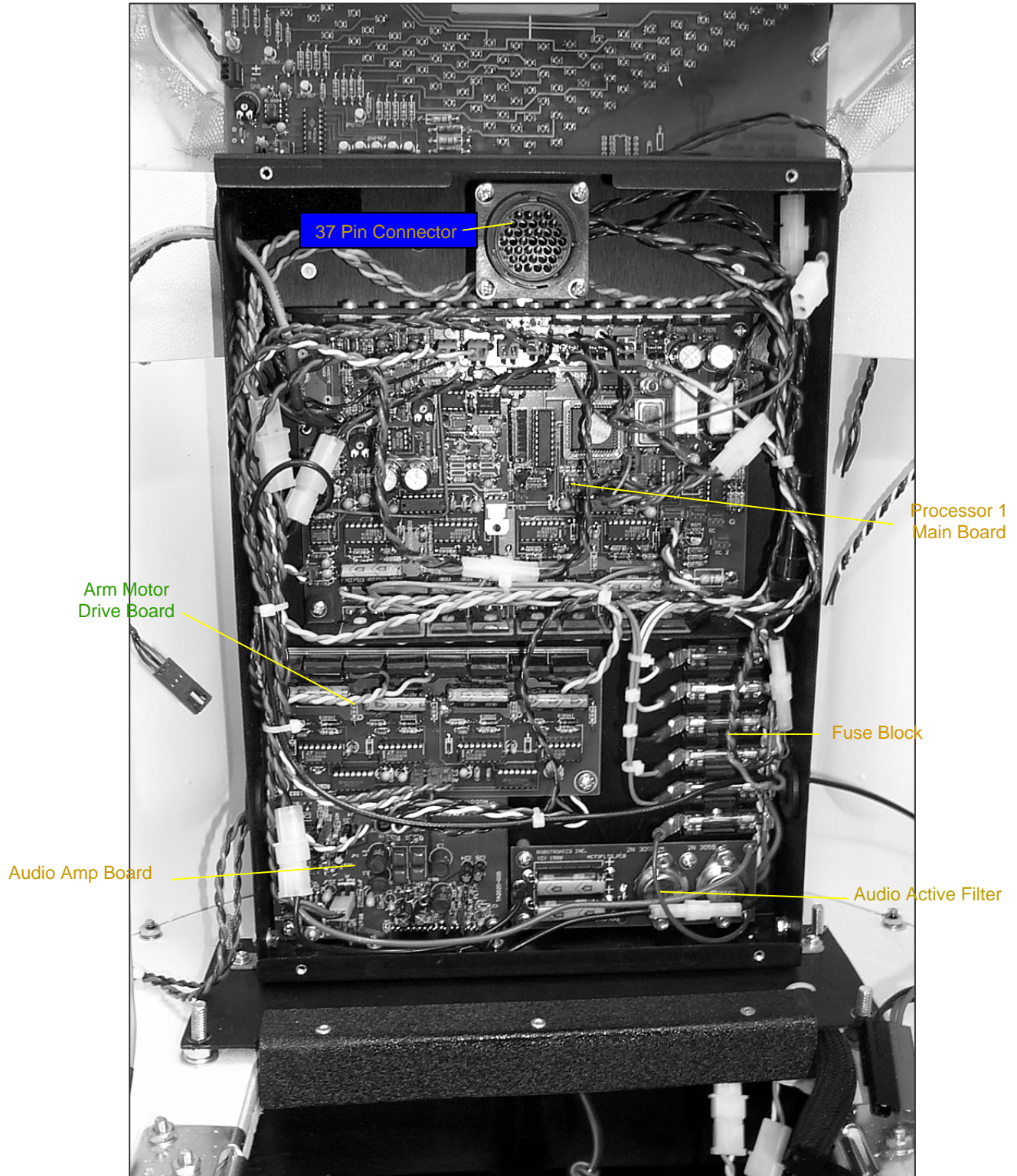



# Fuse Block Detail

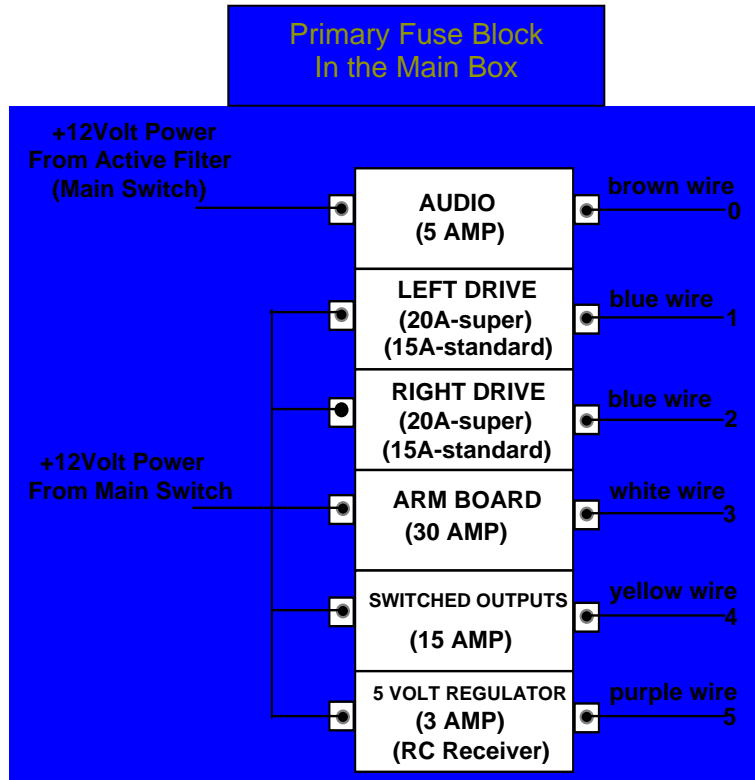

## Primary Fuse Block

Arms Power - (Fuse 3) Power to the arms control circuit board.

Switching Outputs - (Fuse 4) Cassette, siren, dome strobes, programmable electronic display, four dome flashing lights, two dome rapid flashing lights.

5 Volt Regulator - (Fuse 5) The 5 Volt Regulator supplies power for the radio control receiver and main Processor (Processor 1) in the main electronics box.

# Eyes Assembly

## Eyebrows-Eyelids-Eyes L/R

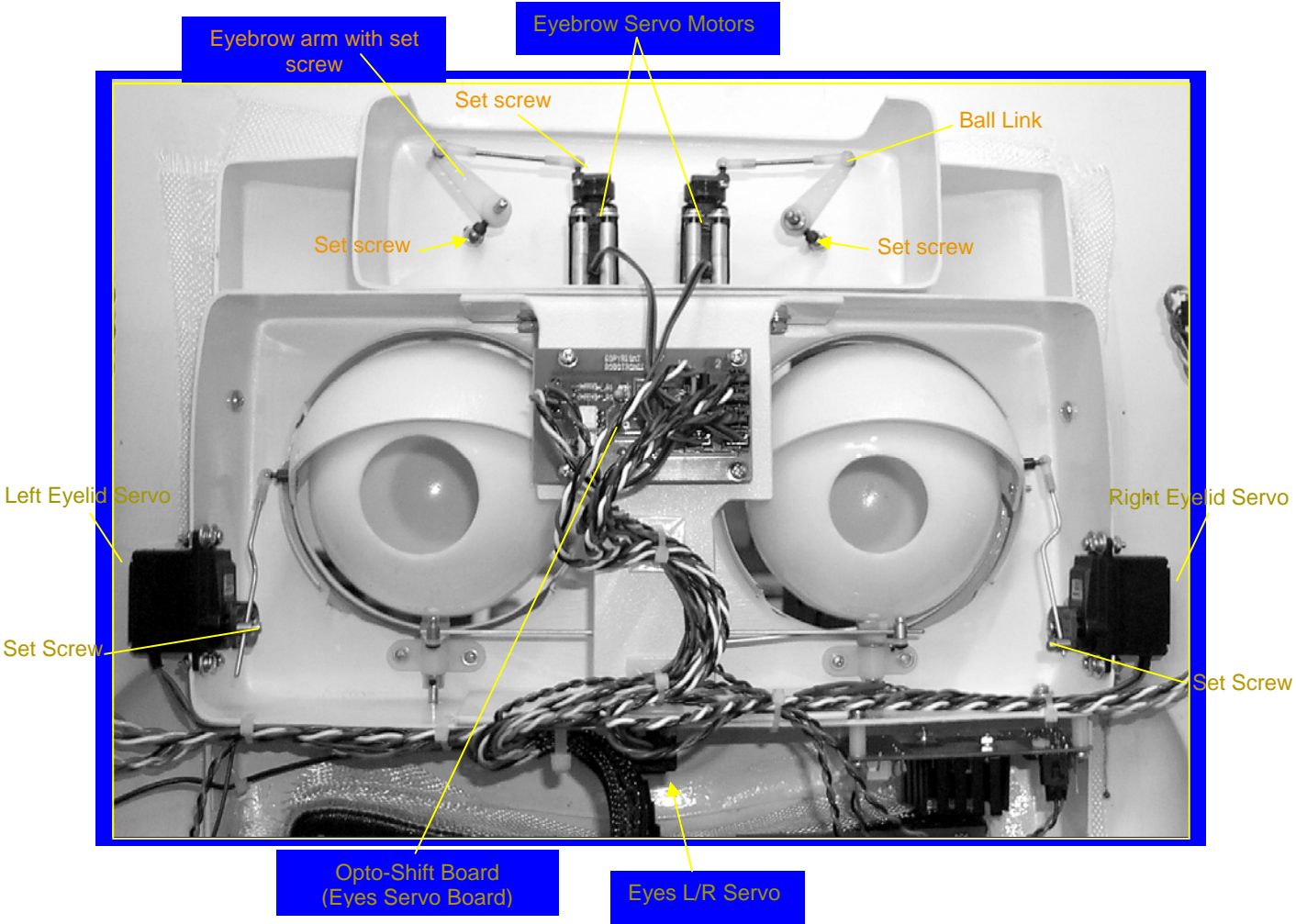

# Eyes Servo Board (Opto-Shift Register Board)

## Version With Two 4 Pin Connections

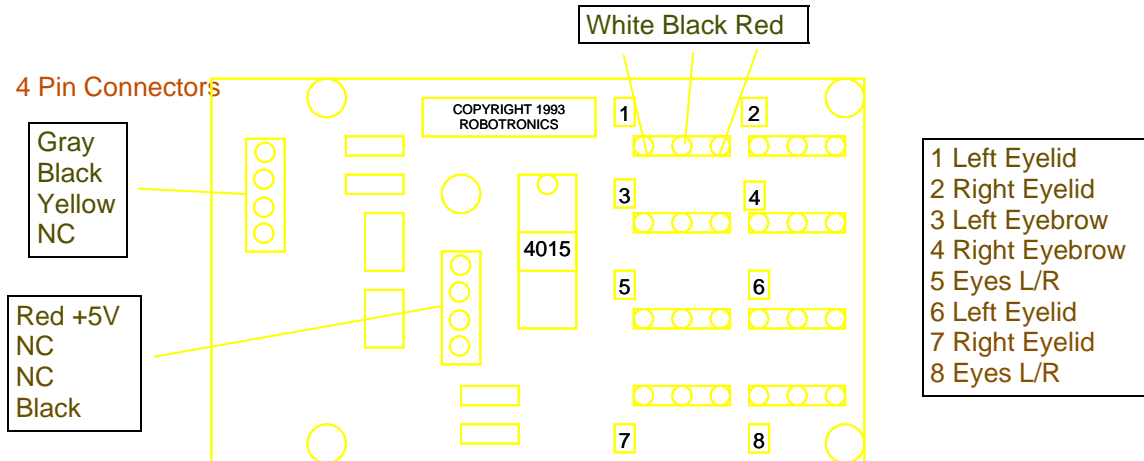

## Version With One 5 Pin Connection

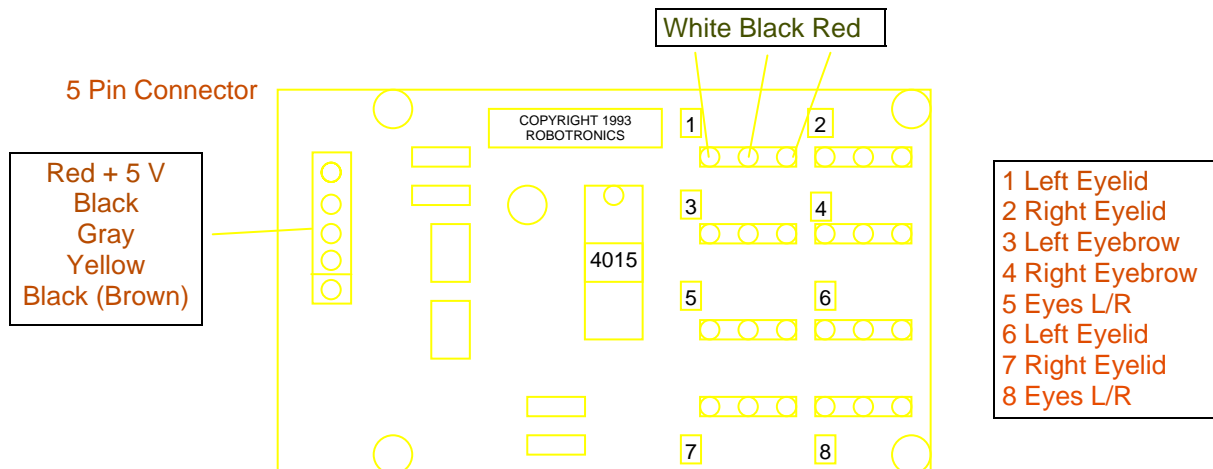

Robot	Typical Connection	Location of Board in Robot
Vehicle	6,7, and 8	In upper robot
Curby & Book	1,2,8, Eyebrows-3 and 4	Below eye mechanism
Standup Robots	1-5	In Chest box
Pluggie	5,6 and 7	On Main Frame

Standups= Safety Sam, McGruff, Freckles, and Gillie

# Lower Base Inside and Bottom View

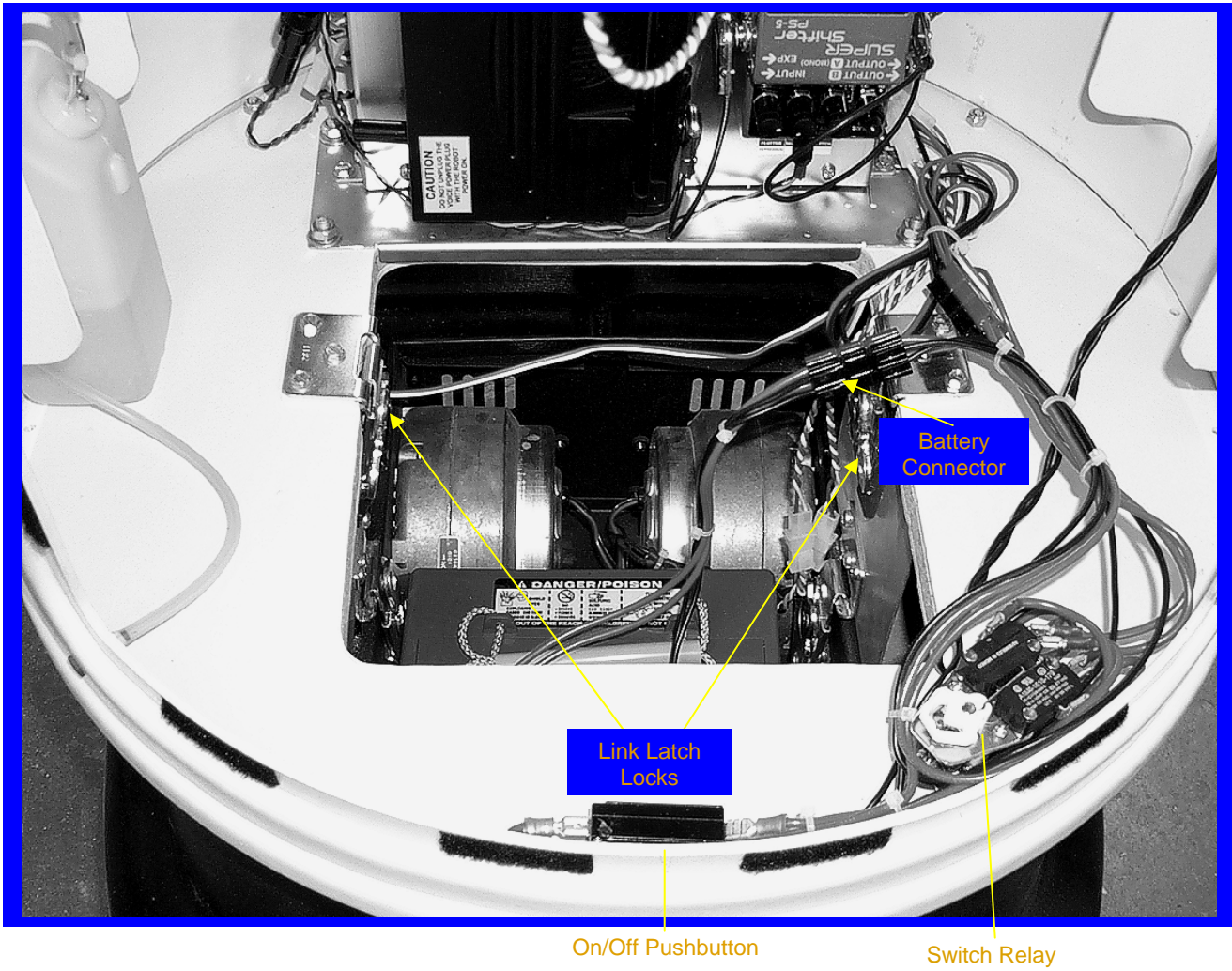

# Drive Base Bottom View

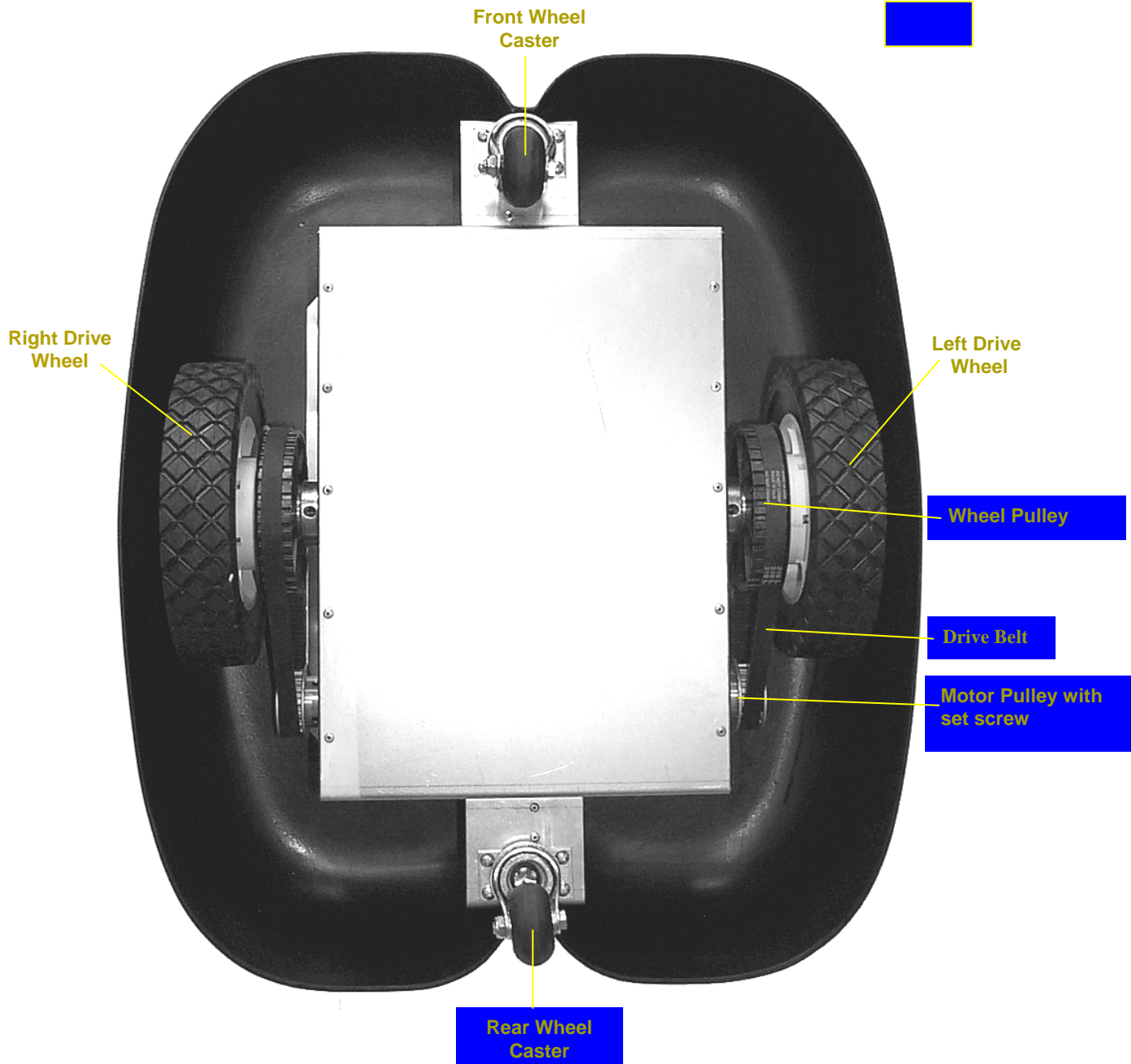

# Notes

# Technical Tips